

# Catalogue 2015



## SUMMARY

	<b>Pages</b>
<b><u>BROKEN TOOL DETECTOR</u></b>	
<u>Broken tool detector Type 101</u>	1
<u>Broken tool detector Type 110</u>	4
<u>Broken tool detector Type 202</u>	7
<u>Accessories for broken tool detector</u>	11
<b><u>LENGTH GAUGE</u></b>	
<u>Length gauge H00 / HOOD / HOODM / HOODS</u>	15
<u>Length gauge V00 / VOOC12</u>	21
<u>Length gauge LOOA / LOOB</u>	25
<u>Length gauge R00 / ROOM</u>	30
<b><u>DIAMETER GAUGE</u></b>	
<u>Diameter gauge FOOS/FOO/FOOL</u>	33
<b><u>GAUGE IN COMPLET KIT</u></b>	<b>39</b>
<b><u>ATTACHMENT ELEMENTS FOR GAUGES</u></b>	<b>53</b>
<b><u>ACCESSORIES FOR GAUGES</u></b>	<b>56</b>
<b><u>INDEX : RESEARCH BY PRODUCT REFERENCE</u></b>	<b>62</b>

# Werkzeugbruchüberwachung Typ 101

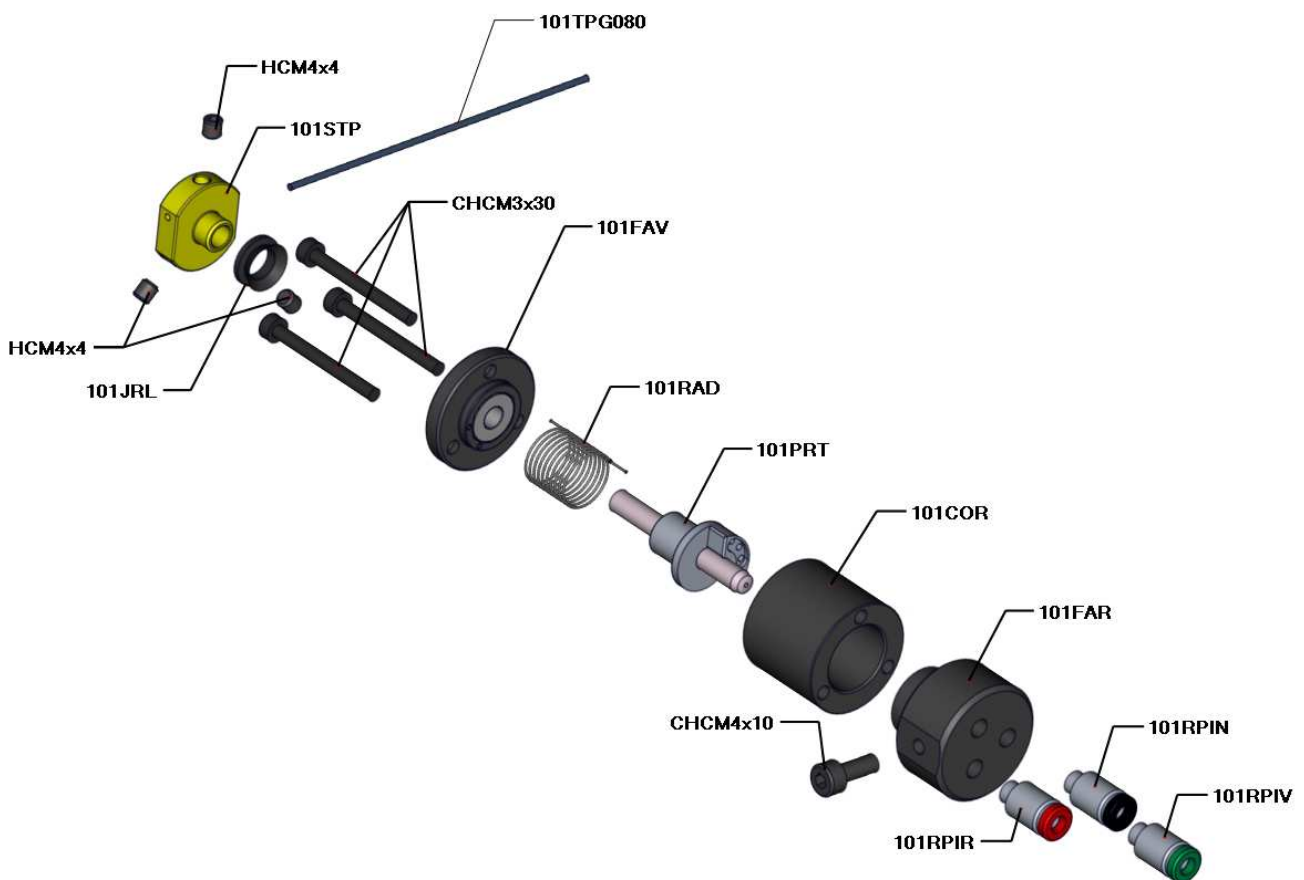
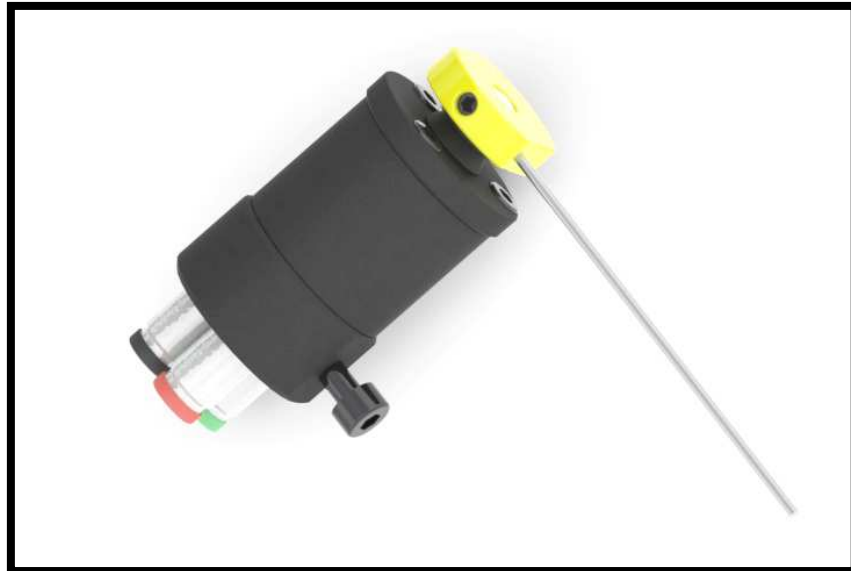

## Broken Tool Detector Type 101



Reference : **101**

Designation : **Broken tool Detector type 101  
COMPLETE KIT**

Application : *101 only*

Sale unit : *x1*

Description : *Complete kit including:*

- 1 body - type 101
- 1 smooth fixing rod 0102TFL + 1 milled fixing rod 101TFF + 1 screw tightening yoke 0102NSEV
- 1 standard pressure switch (activation from 1 bar) 0102PST
- 1 spring for reversing rotation direction
- 1 additional needle



Reference : **101NU**

Designation : **Broken tool detector type 101**

Application : *101 only*

Sale unit : *x1*

Description : *Kit including:*

- 1 body only - type 101

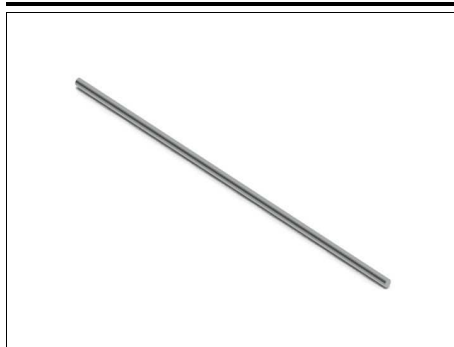

Reference : **101TPG**

Designation : **Needle**

Application : *101 only*

Sale unit : *x10*

- Description :
- 101TPG080X10 : Pack of 10 needles - 80mm length
  - 101TPG120X10 : Pack of 10 needles - 120mm length
  - 101TPG170X10 : Pack of 10 needles - 170mm length
  - 101TPG200X10 : Pack of 10 needles - 200mm length



Reference: **101TPGCHD**

Designation: **Hard chromium plated needle**

Application: *101 only*

Sale unit: *x10*

Description: *101TPG080CHDX10: Pack of 10 needles - 80mm length*  
*101TPG120CHDX10: Pack of 10 needles - 120mm length*  
*101TPG170CHDX10: Pack of 10 needles - 170mm length*  
*101TPG200CHDX10: Pack of 10 needles - 200mm length*



Reference: **101TFF**

Designation: **Milled fixing rod**

Application: *101 only*

Sale unit: *x1*

Description: *165mm length.*

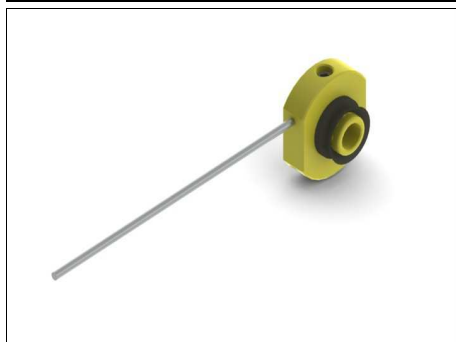

Reference: **101STPX1**

Designation: **Needle support + seal 101JRL + screw + needle**

Application: *101 only*

Sale unit: *x1*

Description:

# Werkzeugbruchüberwachung Typ 110

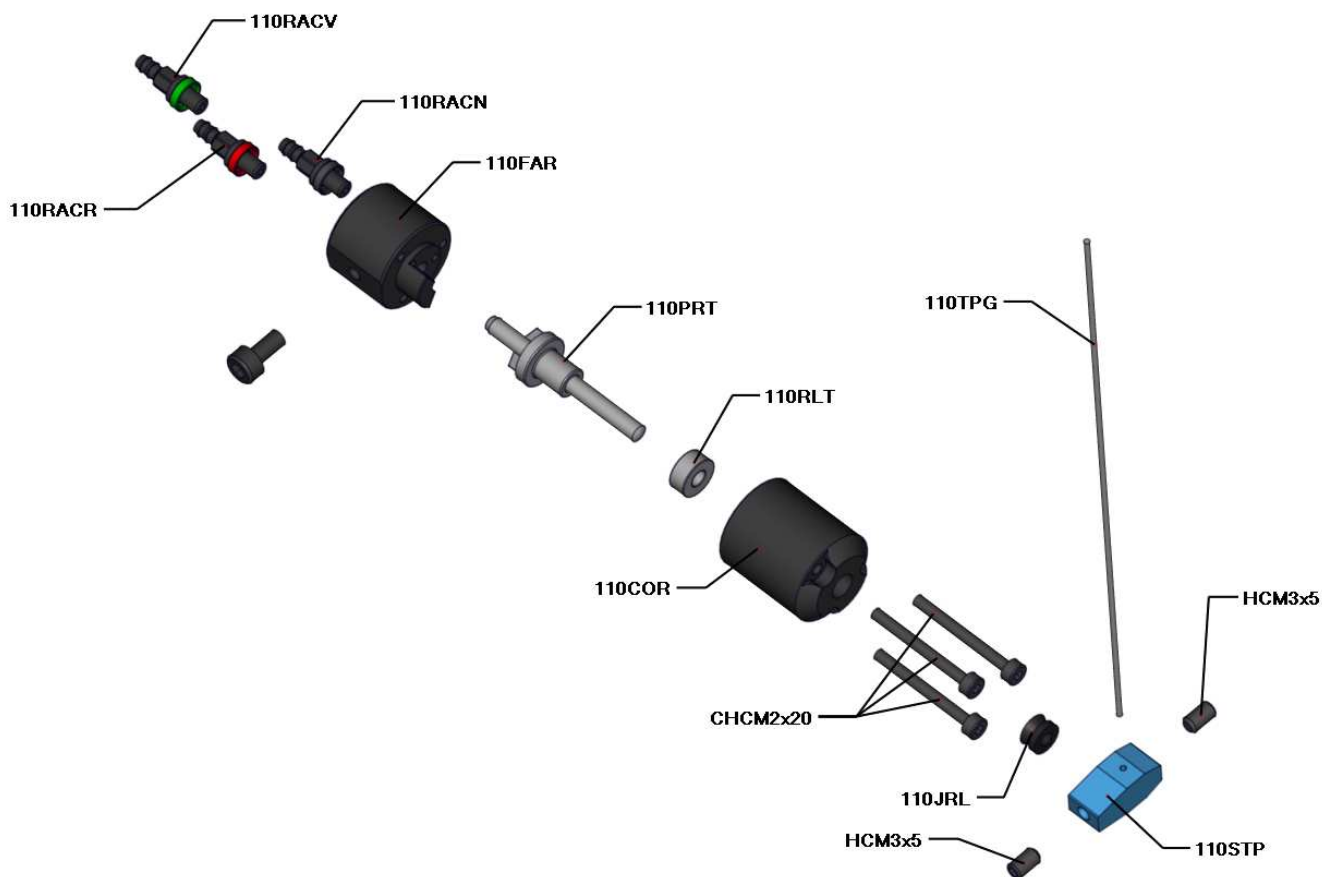
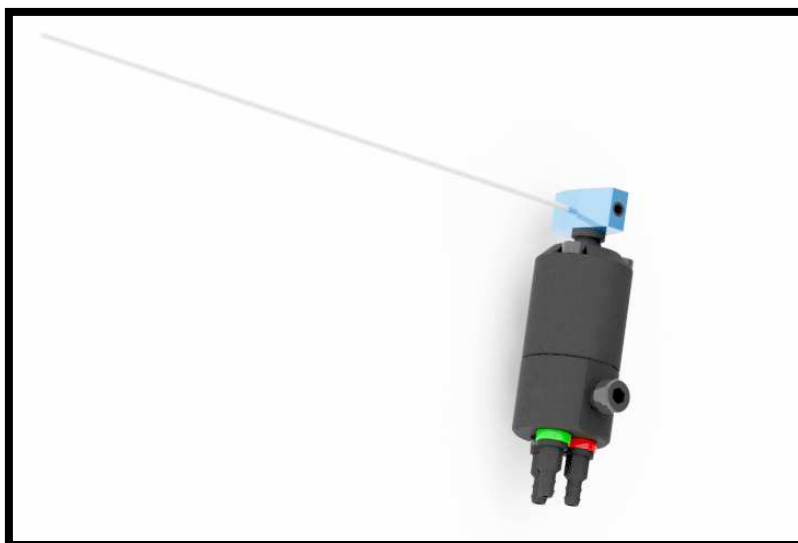

## Broken tool detector Type 110

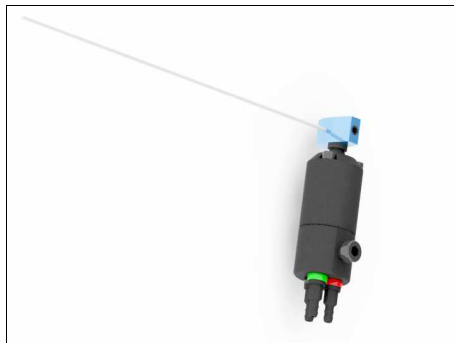

Reference : **110**

Designation : **Broken tool detector type 110**

Application : *110 only*

Sale unit : *x1*

Description : *Complete kit including:*

- 1 body - type 110
- 1 smooth fixing rod 0102TFL+ 1 milled fixing rod 202TFF+ 1 screw tightening yoke 0102NSEV
- 1 standard pressure switch - activation from 1 bar (0102PST)
- 1 spring for reversing rotation direction
- 1 additional needle

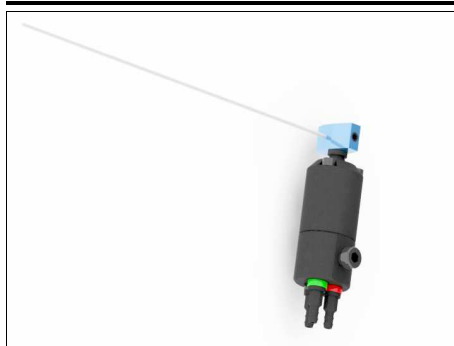

Reference : **110NU**

Designation : **Broken tool detector type 110**

Application : *110 only*

Sale unit : *x1*

Description : *Kit including:*

- 1 body only - type 110

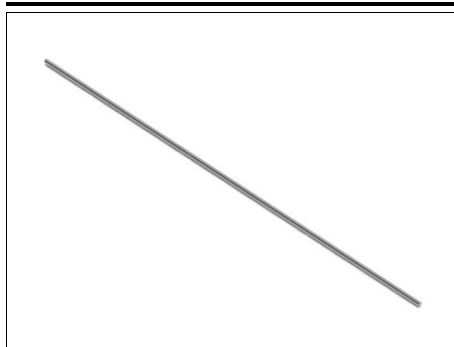

Reference : **110TPG120X10**

Designation : **Needle**

Application : *110 only*

Sale unit : *x10*

Description : *Pack of 10 needles - 120mm length*

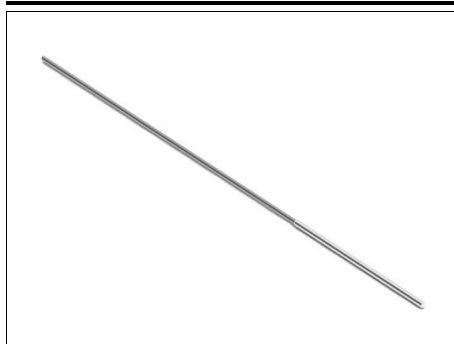

Reference : **110TPG120CHDX10**

Designation : **Hard chromium plated needle**

Application : *110 only*

Sale unit : *x10*

Description : *Pack of 10 hard chromium plated needles - 120mm length*

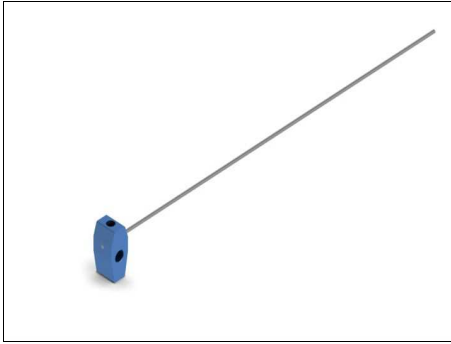

Reference : **110STPX1**

Designation : **Needle support + screw + needle**

Application : *110 only*

Sale unit : *x1*

Description : *Delivered with 2 screws HC M3*

---



Reference : **110JRL**

Designation : **Seal**

Application : *110 only*

Sale unit : *x1*

Description :

---



# Broken tool detector Type 202

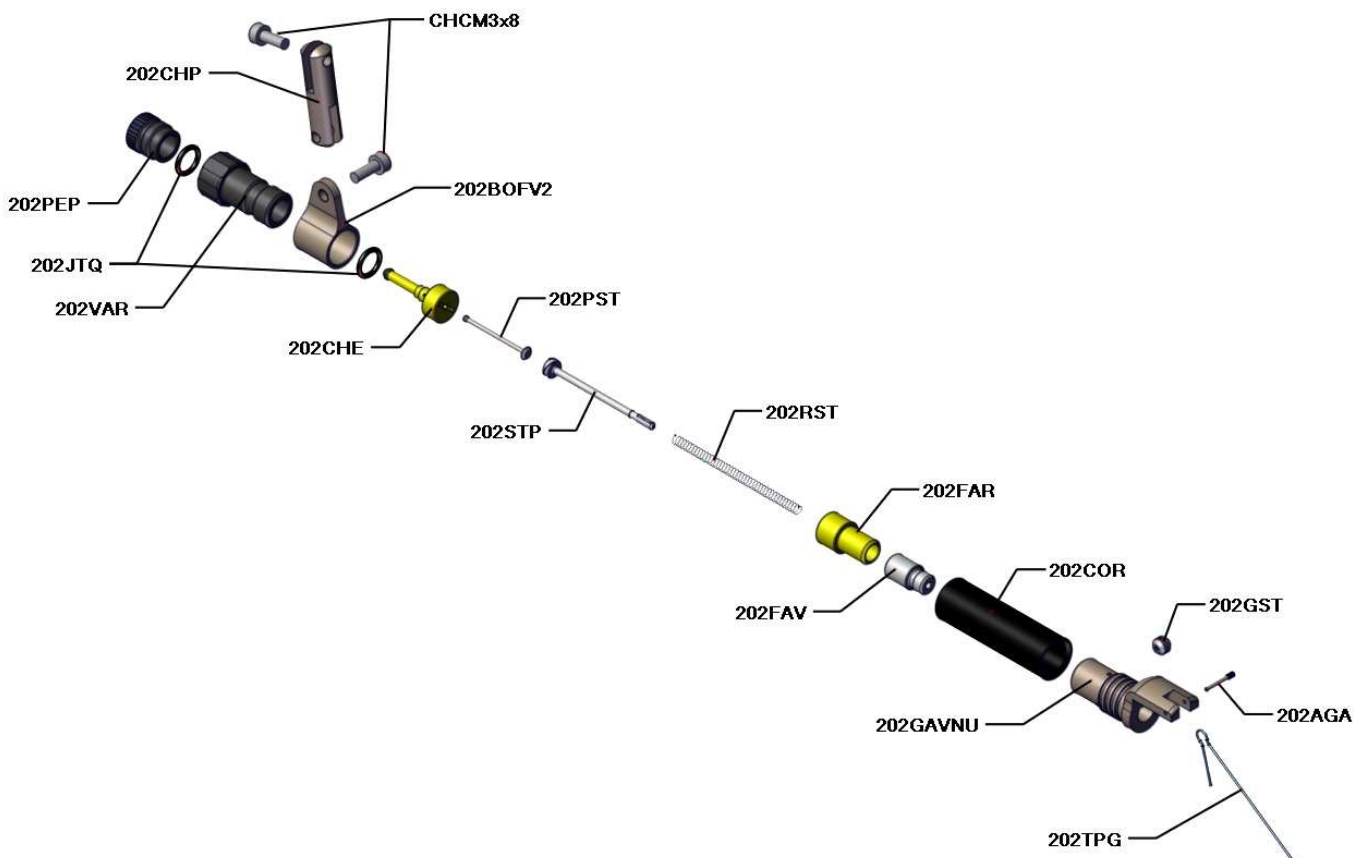

## Broken Tool Detector Type 202



Reference : **202**

Designation : **Broken tool detector type 202**

Application : *202 only*

Sale unit : *x1*

Description : *Complete kit with:*

*-1 body - type 202*

*-1 smooth fixing rod 0102TFL+ 1 milled fixing rod 0102TFF+ 1 tightening yoke 0102NSEV*

*-1,25 meters of coaxial tube 202TCX0125 + 1 Y shaped shunt 202YDD*

*-1 pressure switch (activation 1 bar) 0102PST*

*-6 additional needles*



Reference : **202NU**

Designation : **Broken tool detector type 202**

Application : *202 only*

Sale unit : *x1*

Description : *Kit including:*

*-1 body only - type 202*

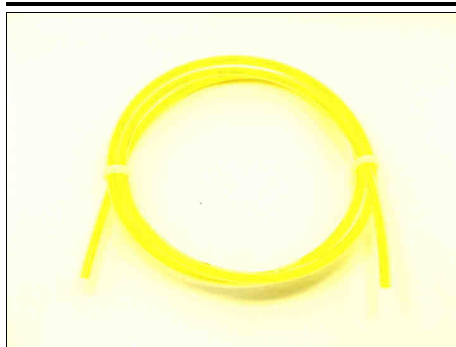

Reference : **202TCX**

Designation : **Coaxial tube**

Application : *202 only*

Sale unit : *x mètre*

Description :



Reference : **202YDD**

Designation : **Y-shaped shunt**

Application : *202 only*

Sale unit : *x1*

Description :



Reference: **202UTC**

Designation: **Union for coaxial tube**

Application: *202 only*

Sale unit: *x1*

Description:

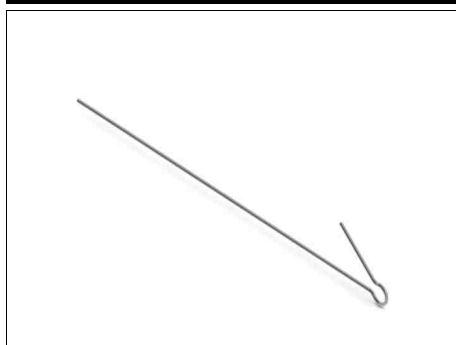

Reference: **202TPG**

Designation: **Needle**

Application: *202 only*

Sale unit: *x100*

Description: *202TPG040X100 : Pack of 100 needles - 40mm length*  
*202TPG060X100 : Pack of 100 needles - 60mm length*  
*202TPG080X100 : Pack of 100 needles - 80mm length*

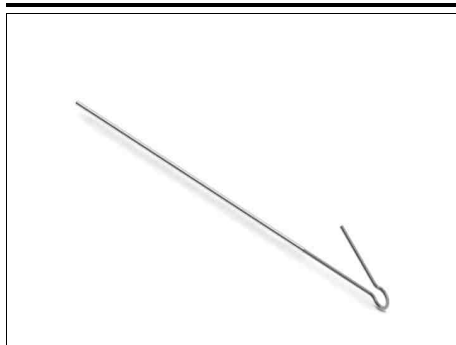

Reference: **202TPGCHD**

Designation: **Hard chromium plated needle**

Application: *202 only*

Sale unit: *x100*

Description: *202TPGCHD040X100 : Pack of 100 hard chromium plated needles - 40mm length*  
*202TPGCHD060X100 : Pack of 100 hard chromium plated needles - 60mm length*  
*202TPGCHD080X100 : Pack of 100 hard chromium plated needles - 80mm length*



Reference: **202TFF**

Designation: **Milled fixing rod**

Application: *202 only*

Sale unit: *x1*

Description: *165mm length*



Reference : **202JTQ**

Designation : **Toric seal**

Application : *202 only*

Sale unit : *x1*

Description : *The seal ensures the pneumatic sealing of the unit. Change it regularly.*

---



Reference : **202PEP**

Designation : **Tightening screw**

Application : *202 only*

Sale unit : *x1*

Description :

---

# Zubehör und Ersatzteile für Werkzeugbruchüberwachung

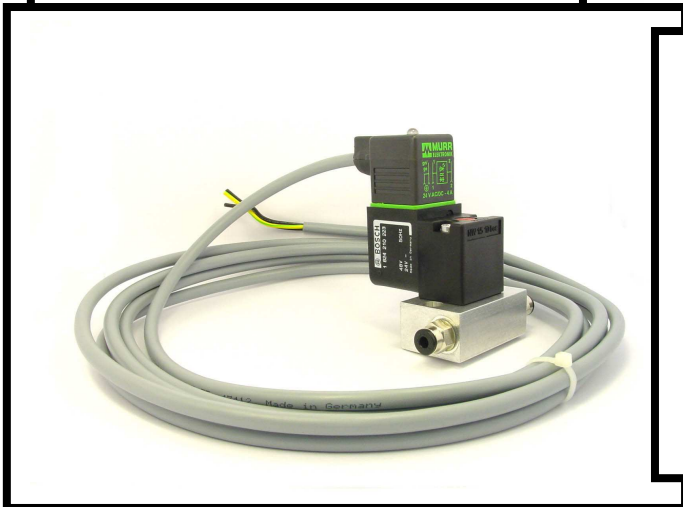
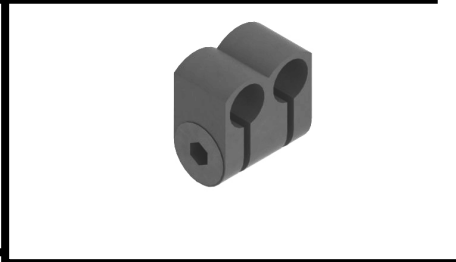
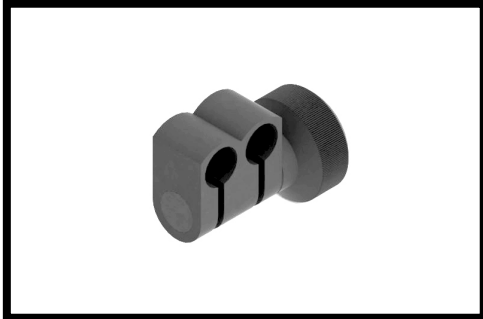

## Accessories for broken tool detectors



Reference : **0102PST**

Designation : **Standard pressure switch**

Application : 101, 110 and 202

Sale unit : x1

Description : *The standard pressure switch converts the pneumatic signal coming from the detector unit to an electrical signal. (Activation from 1 bar)*



Reference : **0102TFL**

Designation : **Smooth fixing rod**

Application : 101, 110 and 202

Sale unit : x1

Description : *This smooth fixing rod is used with a tightening yoke 0102NSEV or 0102NSEM and with a milled fixing rod 101TFF or 202TFF to mount the broken tool detectors 101, 110 and 202.  
165mm length*



Reference : **0102VFTCX1**

Designation : **Short fixing screw**

Application : 101, 110 and 202

Sale unit : x1

Description : *This fixing screw is used only for the Tornos machines type AS14 - SAS16 - SAS16DC - SAS16,6.*

*It replaces the fixing screw of the slide 2 or 3 and allows the mounting of the smooth fixing rod 0102TFL to install the broken tool detectors 101, 110 and 202 without drilling the frame of the machine.*

*See the technical manual for the installation.*



Reference : **0102VFTLX1**

Designation : **Long fixing screw**

Application : 101, 110 and 202

Sale unit : x1

Description : *This fixing screw is used only for the Tornos machines type AS14 - SAS16 - SAS16DC - SAS16,6.*

*It replaces the fixing screw of the slide 1 or 4 and allows the mounting of the smooth fixing rod 0102TFL to install the broken tool detectors 101, 110 and 202 without drilling the frame of the machine.*

*See the technical manual for the installation.*



Reference : **0102NSEMV2**

Designation : **Tightening yoke with a knurled wheel**

Application : 101, 110 and 202

Sale unit : x1

Description : *This tightening yoke with a knurled wheel attaches a smooth fixing rod 0102TFL with a milled fixing rod 101TFF or 202TFF and is used to mount the broken tool detectors 101, 110 and 202.*

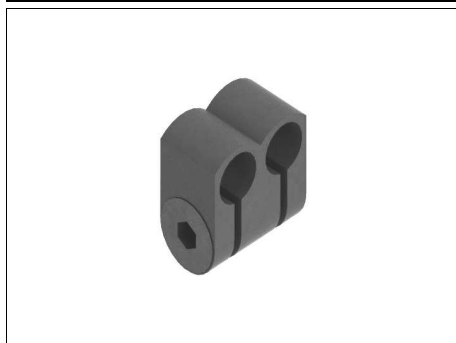

Reference : **0102NSEVV2**

Designation : **Screwed tightening yoke**

Application : 101 and 202

Sale unit : x1

Description : *This tightening yoke with a screw attaches a smooth fixing rod 0102TFL with a milled fixing rod 101TFF or 202TFF and is used to mount the broken tool detectors 101, 110 and 202.*



Reference : **0102EFXGM16X1**

Designation : **Fixing square GM16**

Application : 101, 110 and 202

Sale unit : x1

Description : *This fixing square is used with a smooth fixing rod to install a broken tool detector on the drill holder of a Gildemeister GM16 machine.*



Reference : **0102SAI**

Designation : **Magnetic support**

Application : 101, 110 and 202

Sale unit : x1

Description : *This support is fixed on the frame of the machine to install a broken tool detector without drilling in the frame.*

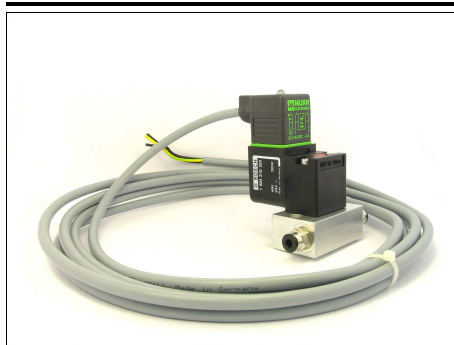

Reference : **0102EEV110**

Designation : **Solenoid valve 110 Volts**

Application : 101, 110 and 202

Sale unit : x1

Description : *This solenoid valve converts the electrical signal into a pneumatic signal to control a broken tool detector. The voltage is 110 volts AC. It is made up of a coil, a pneumatic collar, two plug connections 4x1/8, a solenoid valve and a cable. Also available in 24 volts (Ref.:0102EEV24)*



Reference : **0102KPC**

Designation : **Pressure complete kit**

Application : 101, 110 and 202

Sale unit : x1

Description : *This pressure kit regulates the necessary pressure for the functioning of the broken tool detector (between 4 and 6 bars). It is made up of a regulator valve, a pressure gauge, two plug connections 6x1/8 and a mounting bracket.*



# Length gauge

Type H00 / H00D / H00DM /  
H00DS / V00 / V00C12

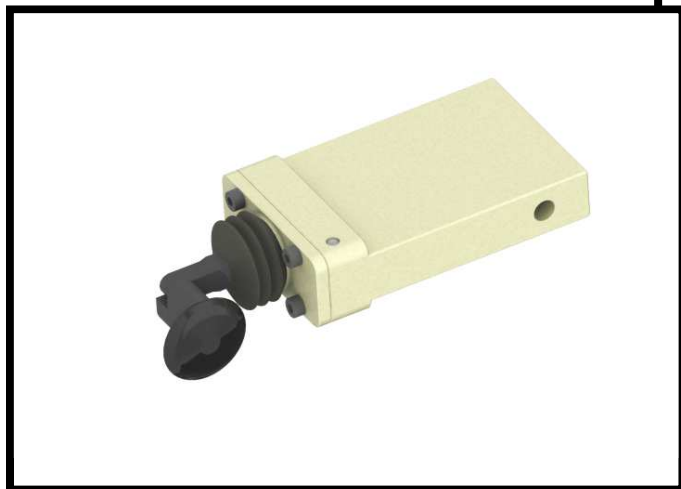
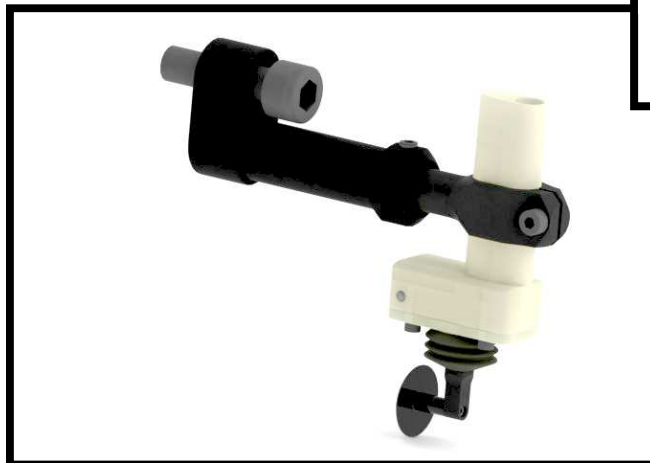
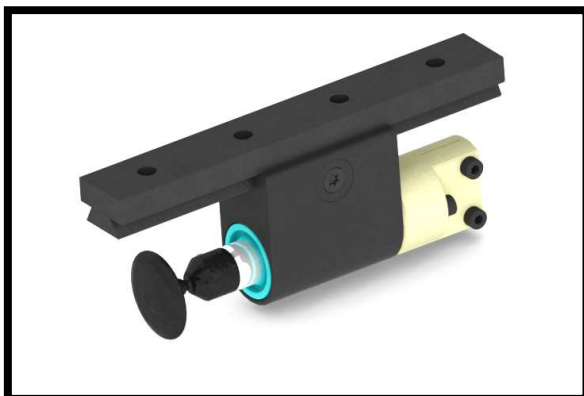

# Length gauge Type H00 / H00D / H00DM / H00DS

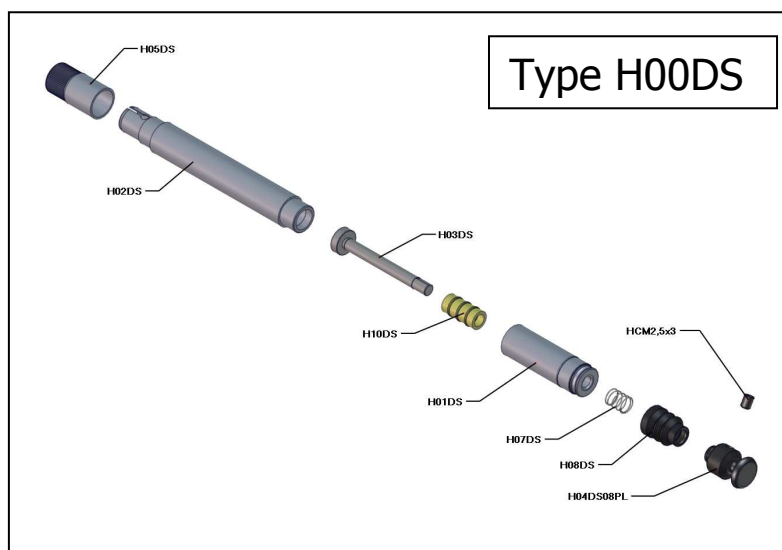
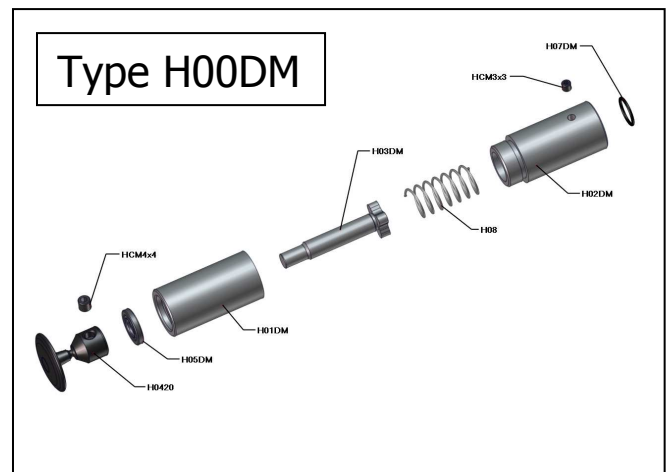
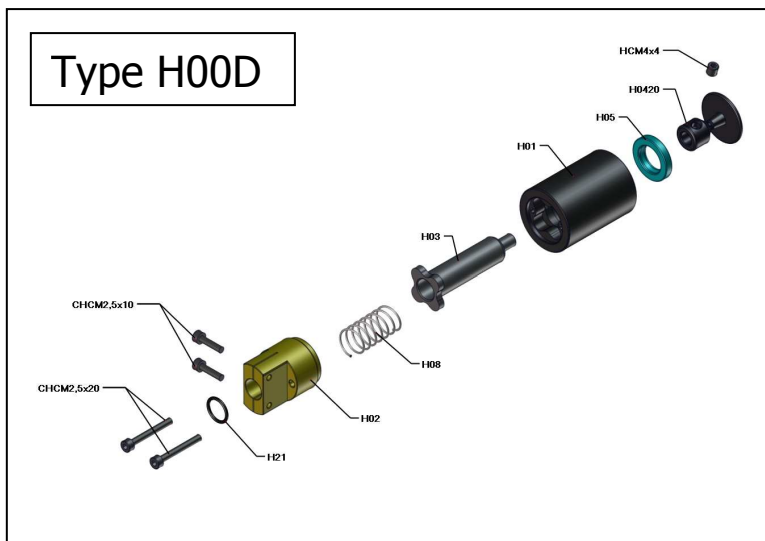
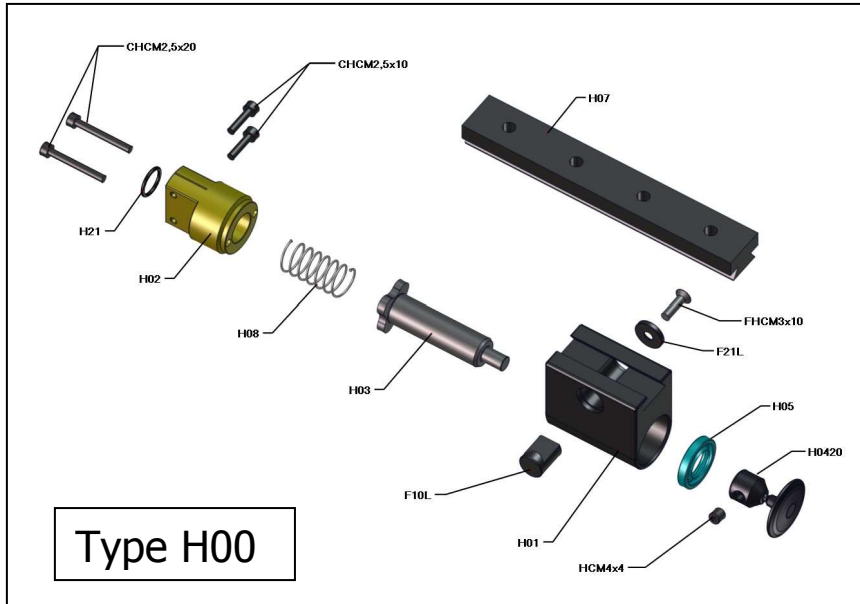

## Length Gauge

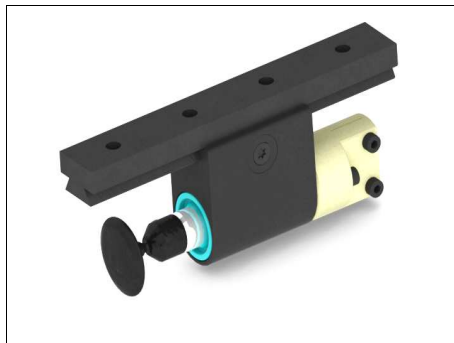

Reference : **H00**

Designation : **Probe H00**

Application : *Length measurement on the fly*

Sale unit : x1

Description : *This probe H00 is used to measure part length. It mounts horizontally between 2 stations for measurement on the fly. It is used with the internal sensor and amplifier.*



Reference : **H00D**

Designation : **Probe H00D**

Application : *Length measurement at station*

Sale unit : x1

Description : *This Probe H00D is used to measure part length. It mounts horizontally between 2 stations for measurement on the fly. It is used with the internal sensor and amplifier.*



Reference : **H00DM**

Designation : **Probe H00DM**

Application : *Length measurement at station*

Sale unit : x1

Description : *This probe H00DM is used to measure part length. It mounts horizontally like a drilling tool (Ø16) for measurement at the station. It is used with the internal sensor and amplifier.*



Reference : **H00DS**

Designation : **Probe H00DS**

Application : *Length measurement at station*

Sale unit : x1

Description : *This probe is used to measure part length. It mounts horizontally like a drilling tool (Ø8) for measurement at the station. It is used with the internal sensor and amplifier.*



Reference : **H0420X1**

Designation : **Probe tip Ø20 (standard)**

Application : *H00 / H00D / H00DM*

Sale unit : *x1*

Description : *This tip is used for measurement in process or at station.*



Reference : **H0420PLX1**

Designation : **Dish probe tip Ø20**

Application : *H00D and H00DM*

Sale unit : *x1*

Description : *This tip is used only for measurement at station.*



Reference : **H0410X1**

Designation : **Probe tip Ø10mm**

Application : *H00 / H00D / H00DM*

Sale unit : *x1*

Description : *This tip is used for measurement at station or in process.*



Reference : **H0410PLX1**

Designation : **Dish probe tip Ø10**

Application : *H00D and H00DM at station*

Sale unit : *x1*

Description : *This tip is used only for a measurement at station.*



Reference : **H04DS08PLX1**

Designation : **Dish probe tip Ø8**

Application : *H00DS only*

Sale unit : *x1*

Description : *This tip is used only for measurement at station.*



Reference : **H04DS08X1**

Designation : **Probe tip Ø8**

Application : *H00DS only*

Sale unit : *x1*

Description : *This tip is used for measurement at station or in process.*



Reference : **H07**

Designation : **Standard dovetail slide**

Application : *H00 and F00L*

Sale unit : *x1*

Description : *This slide is fixed on the mounting bracket. It allows the precise movement of the probe during installation and part setup. The position is locked by the tightening of the clamp.*



Reference : **H07DM**

Designation : **Toric seal**

Application : *H00DM only*

Sale unit : *x1*

Description : *This seal is situated at the back of the probe H00DM to protect the sensor from contamination.*



Reference : **H05DS**

Designation : **Tightening nut**

Application : *H00DS only*

Sale unit : *x1*

Description : *It is used to tighten the sensor to the body of the probe.*



Reference : **H07DS**

Designation : **Return spring**

Application : *H00DS only*

Sale unit : *x1*

Description : *This spring returns the piston of the probe to its starting position.*



Reference : **H08DS**

Designation : **Protective bellow**

Application : *H00DS only*

Sale unit : *x1*

Description : *The bellow protects the unit from contamination. A bellow in good condition is necessary to assure proper performance.*

# Length gauge Type V00 / Type V00C12

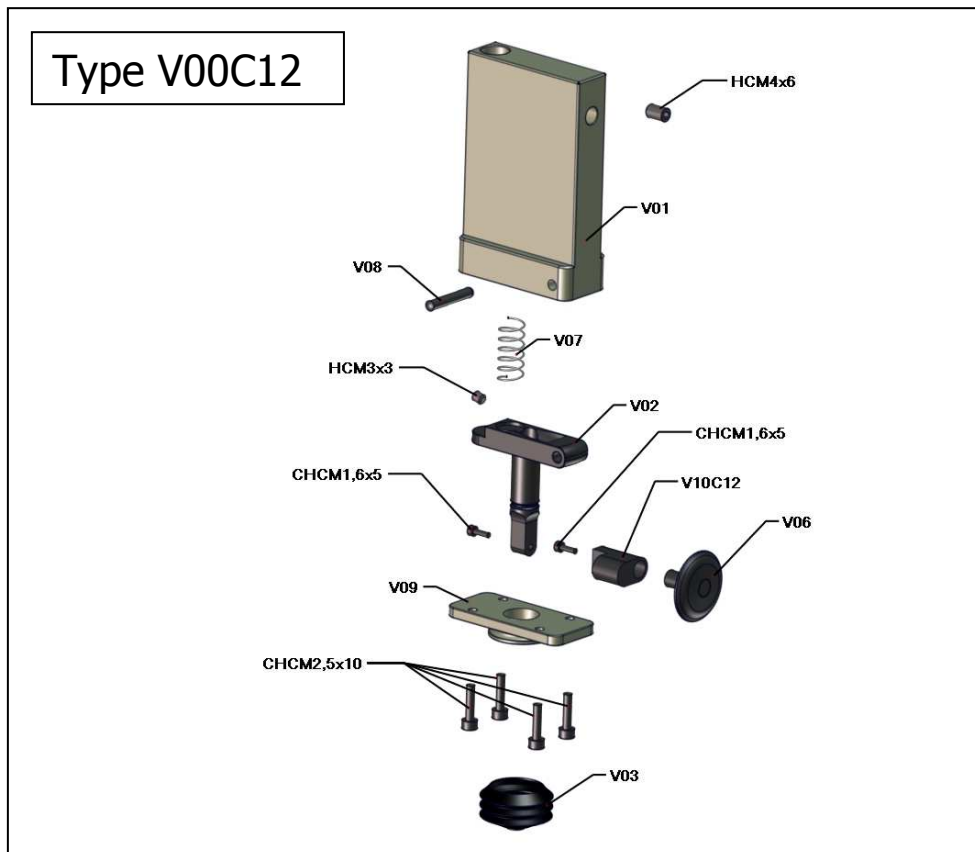
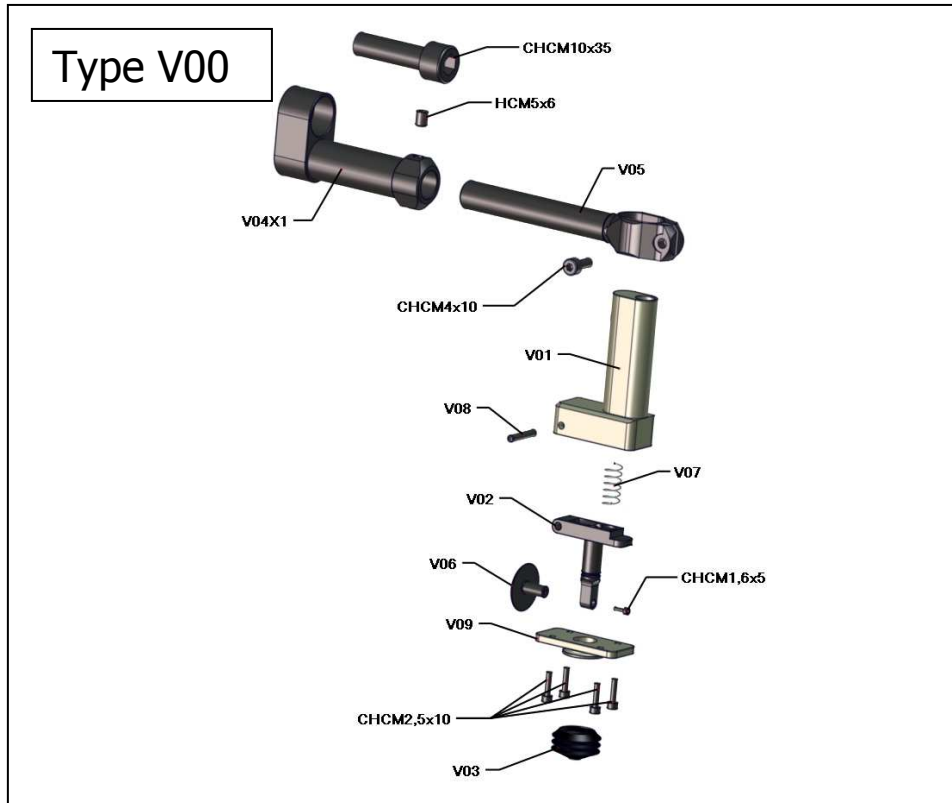



Reference : **V00**

Designation : **Probe V00**

Application : *Length measurement in process*

Sale unit : x1

Description : *This probe V00 is used to measure part length.  
It is installed vertically between 2 stations for measurement in process.  
It is used in conjunction with the internal sensor and an amplifier.*



Reference : **V00C12**

Designation : **Probe V00C12**

Application : *Length measurement at station*

Sale unit : x1

Description : *This probe V00C12 is used to measure part length.  
It is installed in a tool holder type 12mm square fixed on a slide like a plunging tool  
for length measurement at station.  
It is used in conjunction with the internal sensor and an amplifier.*



Reference : **V06X1**

Designation : **Probe tip - Ø 20**

Application : *V00 and V00C12*

Sale unit : x1

Description : *Supply with 1 screw CHC M1,6x5.*



Reference : **V06R22X1**

Designation : **Probe tip - Ø 20 + extension**

Application : *V00 and V00C12*

Sale unit : x1

Description : *Supply with 1 screw CHC M1,6x5.*





Reference : **CHCM1.6X5X10**

Designation : **Screw CHC M1,6x5**

Application : *V00 and V00C12*

Sale unit : *x10*

Description : *This screw is used to fix the probe tip V06X1 on the contact holder return arm V02X1.*



Reference : **V03**

Designation : **Protective bellow**

Application : *V00 and V00C12*

Sale unit : *x1*

Description : *The bellow protects the unit from contamination. It is imperative to have a bellow in good condition to assure the good working of the probe.*



Reference : **V04X1**

Designation : **Mounting body**

Application : *V00 only*

Sale unit : *x1*

Description : *Delivered with 1 screw CHC M10x35*



Reference : **V05X1**

Designation : **Mounting post**

Application : *V00 only*

Sale unit : *x1*

Description :



Reference : **V02X1**

Designation : **Contact holder return arm**

Application : *V00 and V00C12*

Sale unit : *x1*

Description : *The contact holder return arm moves during measurement. The probe tip V06X1 is fixed to this holder.*



Reference : **V10C12**

Designation : **Adapter of probe tip**

Application : *V00C12 only*

Sale unit : *x1*

Description : *The adapter is used to align the center of the probe with the one of the piece to be measured.*

# Length gauge Type L00A / Type L00B

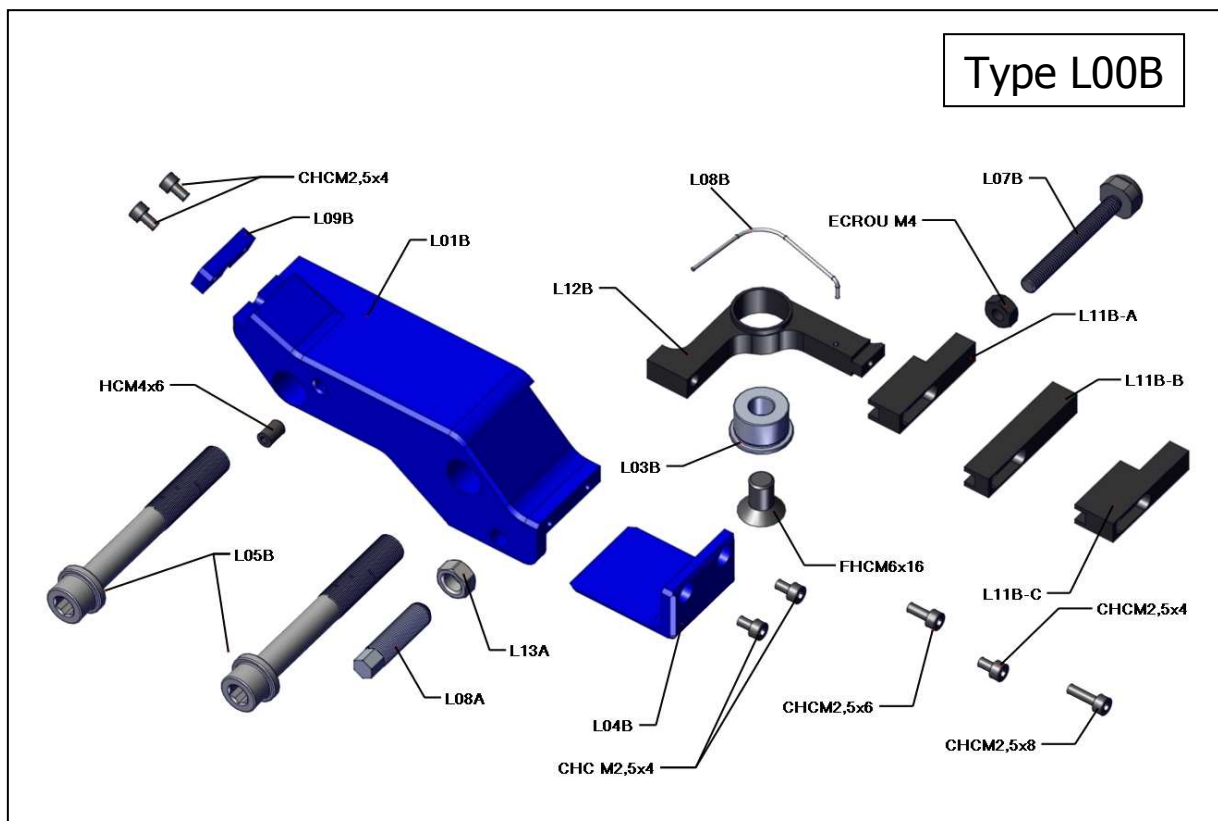
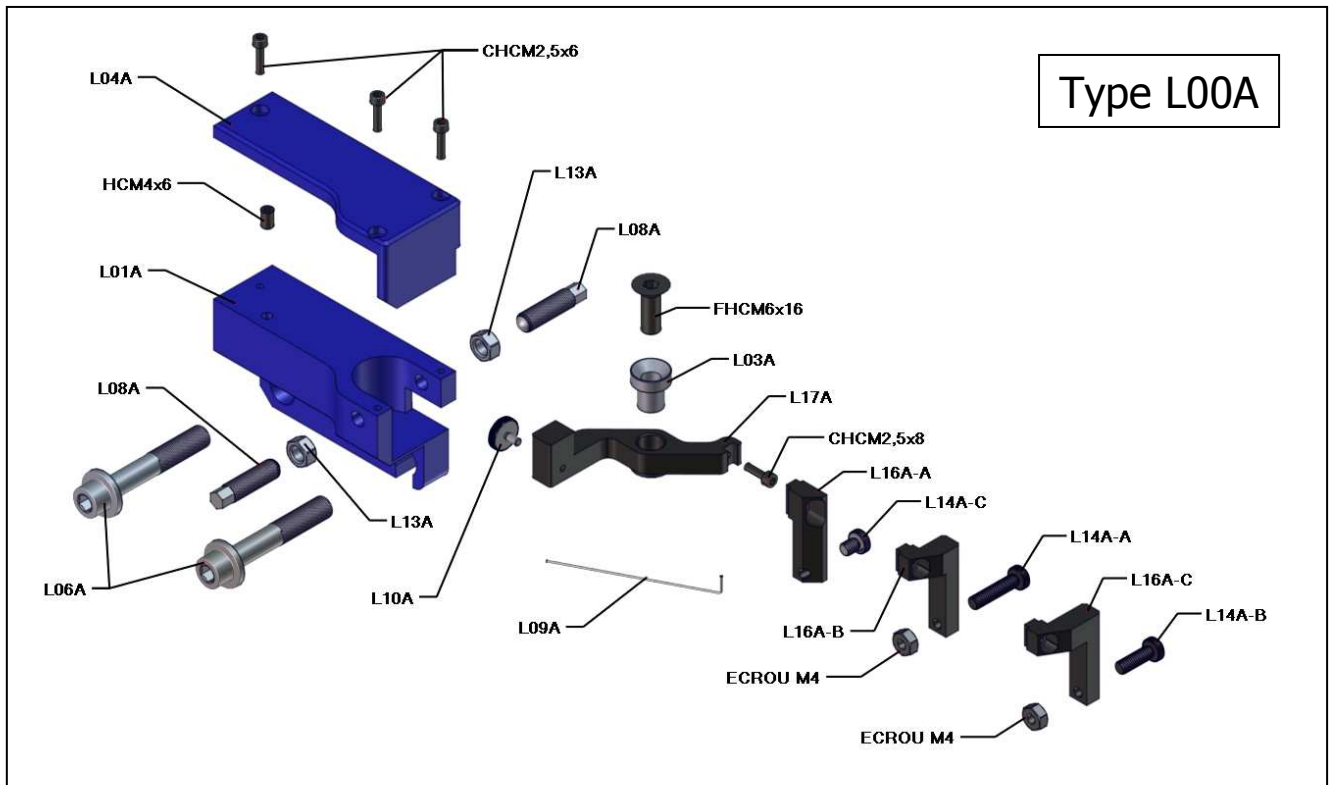

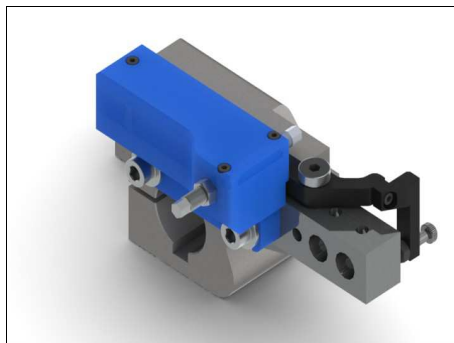

Reference : **L00A**

Designation : **L00A mechanical probe for the Tornos SAS16.6 counter spindle lever**

Application : *Length measurement on the fly*

Sale unit : x1

Description : *This probe is used to measure part length on the fly on a TORNOS SAS16.6 machine. It is installed on the counter spindle lever. It is used in conjunction with the Detector internal sensor and amplifier.*

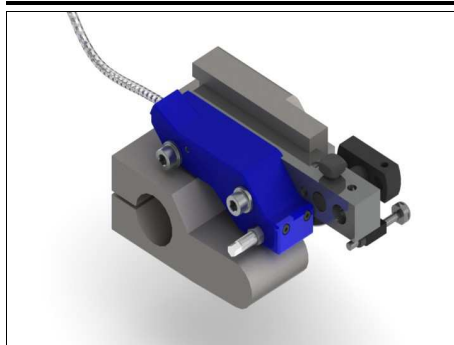

Reference : **L00B**

Designation : **L00b mechanical probe for the Tornos SAS16.6 counter spindle lever**

Application : *Length measurement on the fly*

Sale unit : x1

Description : *This probe is used to measure part length on the fly on a TORNOS SAS16.6 machine. It is installed on the counter spindle lever. It is used in conjunction with the Detector internal sensor and amplifier.*

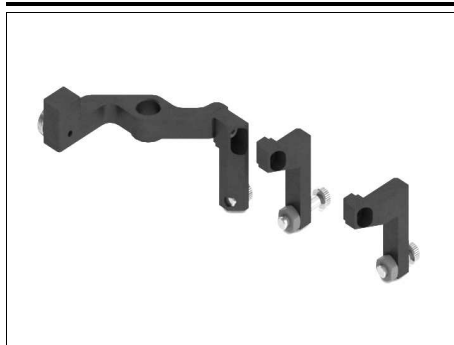

Reference : **L17AX1**

Designation : **Measuring arm + tip**

Application : *L00A only*

Sale unit : x1

Description : *It displaces the internal sensor tip with the movement of the measuring arm contact.*

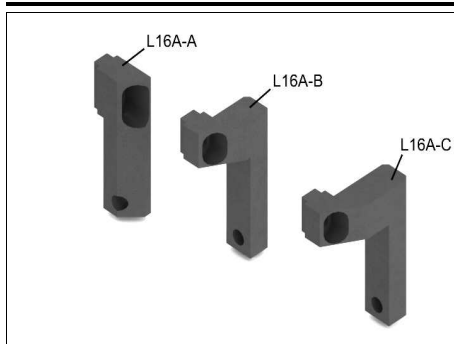

Reference : **L16A**

Designation : **Tip of measure**

Application : *L00A only*

Sale unit : x1

Description : *Interchangeable tip setting in end of measuring arm*



Reference : **L14A-A**

Designation : **Contact tip**

Application : *L00A only*

Sale unit : *x1*

Description : *This tip contact*

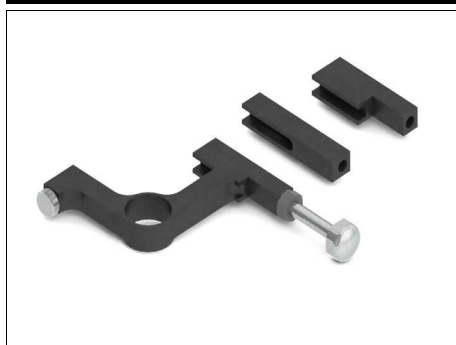

Reference : **L12BX1**

Designation : **Measuring arm + tip**

Application : *L00B only*

Sale unit : *x1*

Description : *It displaces the internal sensor tip with the movement of the measuring arm contact.*

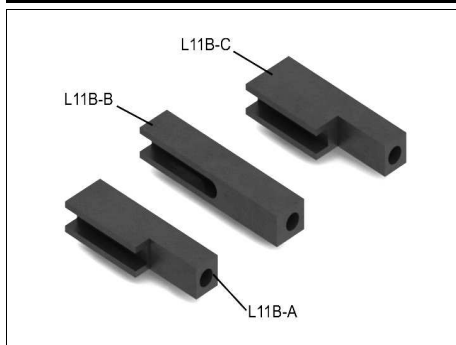

Reference : **L11B**

Designation : **Tip of measure**

Application : *L00B only*

Sale unit : *x1*

Description : *Interchangeable tip setting in end of measuring arm*



Reference : **L07BX1**

Designation : **Contact tip + M4 nut**

Application : *L00B only*

Sale unit : *x1*

Description : *This tip contact the part to be measured.*



Reference : **L03A**

Designation : **Guide ring**

Application : *L00A only*

Sale unit : *x1*

Description : *It guides the measurement arm in its rotation. It is mounted with a screw FHC M6x20 on the drill holder lever of the machine*



Reference : **L03B**

Designation : **Guide ring**

Application : *L00B only*

Sale unit : *x1*

Description : *It guides the measurement arm in its rotation. It is mounted with a screw FHC M6x20 on the drill holder lever of the machine*



Reference : **L06A**

Designation : **Fixing screw M7-0,5x40**

Application : *L00A only*

Sale unit : *x1*

Description : *It is used to mount the complet unit onto the drill-holder lever.*



Reference : **L05B**

Designation : **Fixing screw M7x0,5x53**

Application : *L00B only*

Sale unit : *x1*

Description : *It is used to mount the complet unit onto the drill-holder lever.*



Reference : **L08A**

Designation : **Screw H M6-0,5x25**

Application : *L00A and L00B*

Sale unit : *x1*

Description : *It is used to adjust and lock the probe position on the lever.*

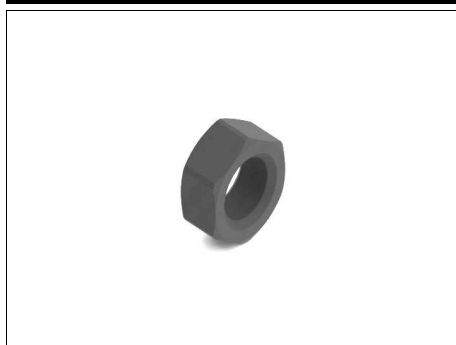

Reference : **L13A**

Designation : **Nut M6x0,5**

Application : *L00A and L00B*

Sale unit : *x1*

Description : *It is used to clamp the adjustment screws L08A.*

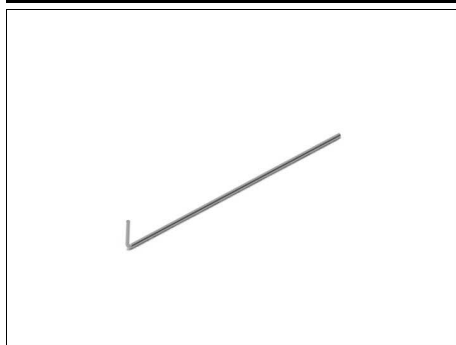

Reference : **L09A**

Designation : **Return spring**

Application : *L00A only*

Sale unit : *x1*

Description : *It brings the lever to its return position.*

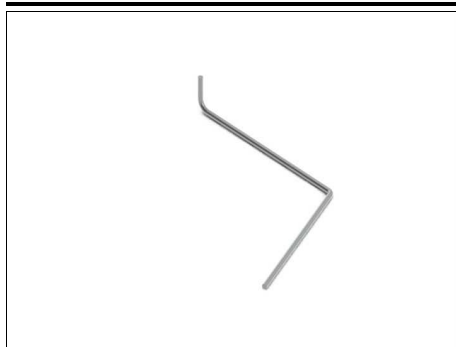

Reference : **L08B**

Designation : **Return spring**

Application : *L00B only*

Sale unit : *x1*

Description : *It brings the lever to its return position.*

# Length gauge Type R00 / Type R00M

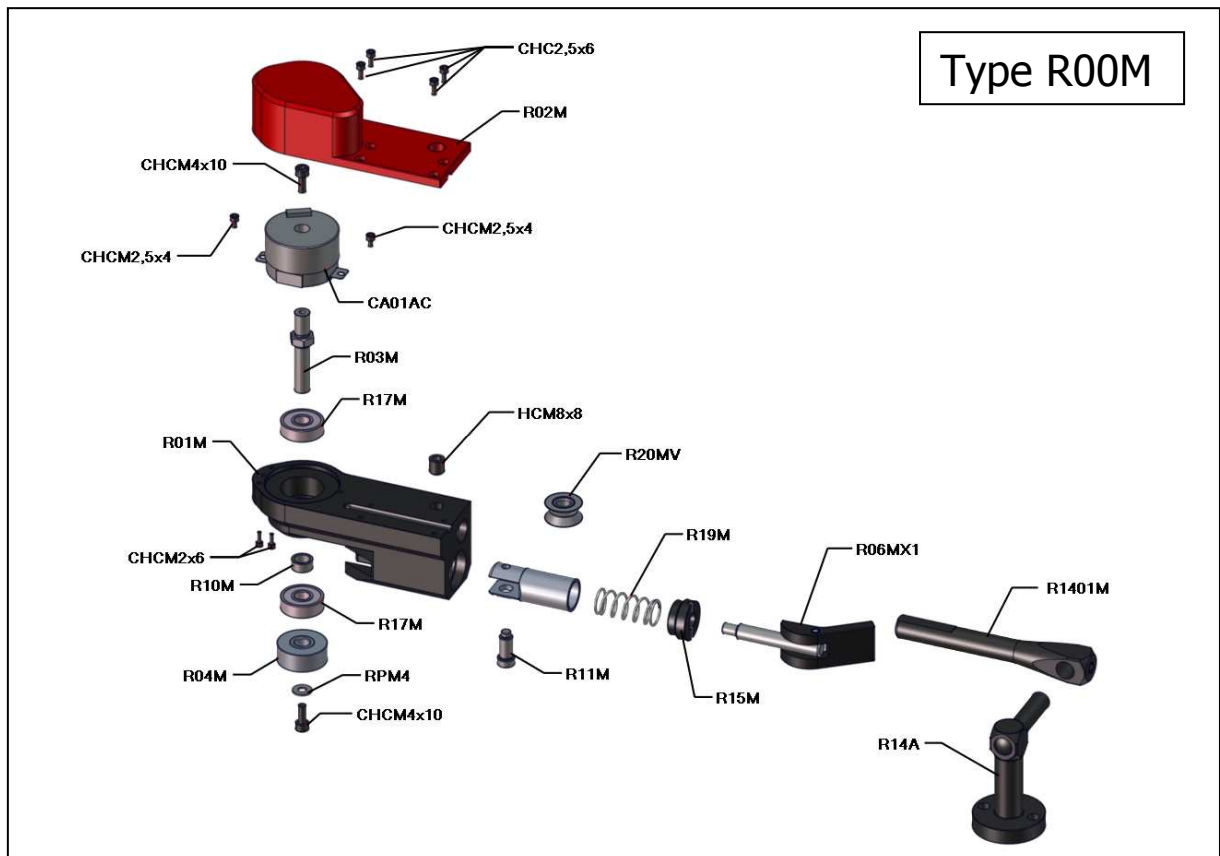
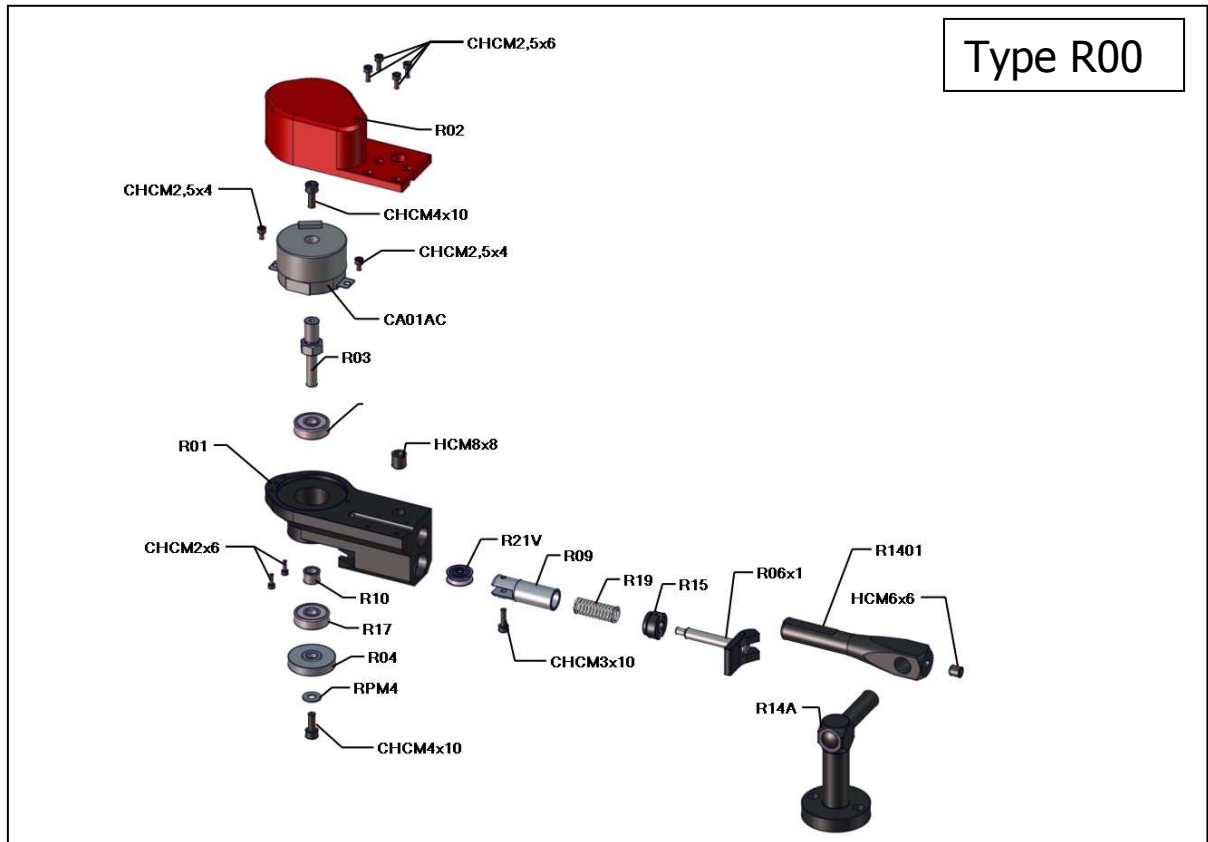





Reference : **R00**

Designation : **Length gauge**

Application : *Length gauge for escomatic machines*

Sale unit : x1

Description : *It allows to measure one or several lengthes (4 maxi.) linked at the wire feedout. It is compatible with the D2, D4 and Newmac Esco machines.*



Reference : **ROOM**

Designation : **Length gauge**

Application : *Length gauge for escomatic machines*

Sale unit : x1

Description : *It allows to measure one or several lengthes (4 maxi.) linked at the wire feedout. It is compatible with the Eubama machines.*

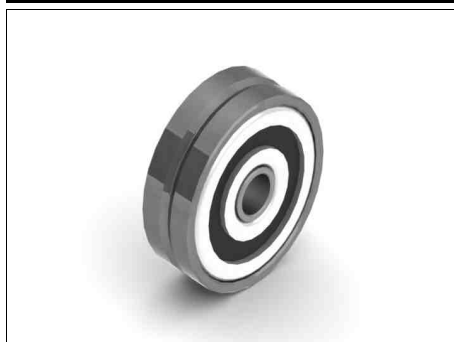

Reference : **R24**

Designation : **Tightening running wheel Ø0,4 à Ø2**

Application : *R00 only*

Sale unit : x1

Description : *It allows to keep the wire against the measurement running wheel. Its V shape increases the tightening of the bar against the measurement running wheel. It can be used with 0,4mm to 2mm diameter wire.*

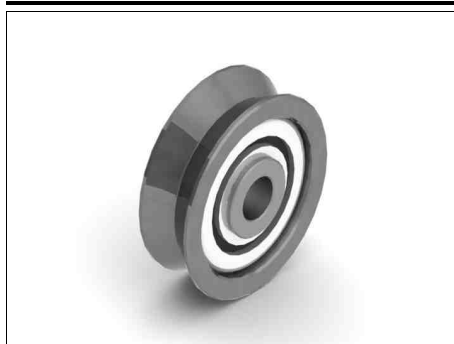

Reference : **R25**

Designation : **Tightening running wheel V Ø1,2 à Ø7**

Application : *R00 only*

Sale unit : x1

Description : *It allows to keep the wire against the measurement running wheel. Its V shape increases the tightening of the bar against the measurement running wheel. It can be used with 1,2mm to 7mm diameter wire.*

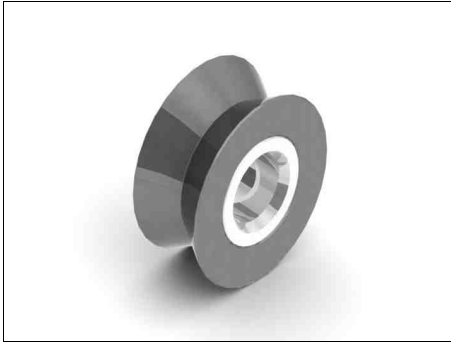

Reference: **R20MV**

Designation: **Tightening running wheel V Ø2,5 à Ø14**

Application: *ROOM only*

Sale unit: *x1*

Description: *It allows to keep the wire against the measurement running wheel. Its V shape increases the tightening of the bar against the measurement running wheel. It can be used with 2,5mm to 14mm diameter wire.*

---

# Diameter gauge Type FOOS / Type F00 / Type FOOL

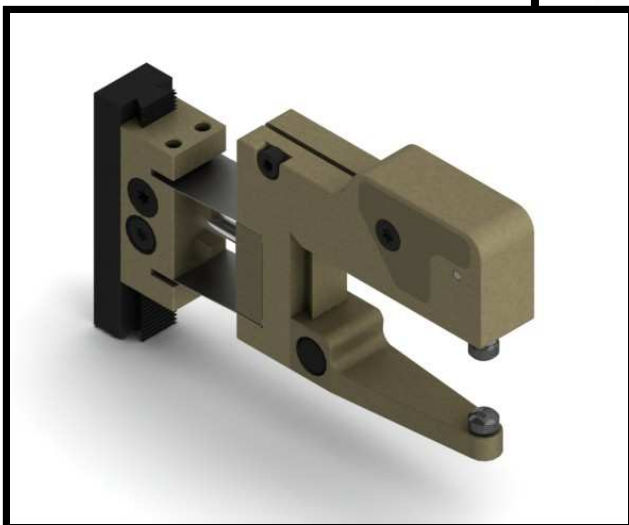
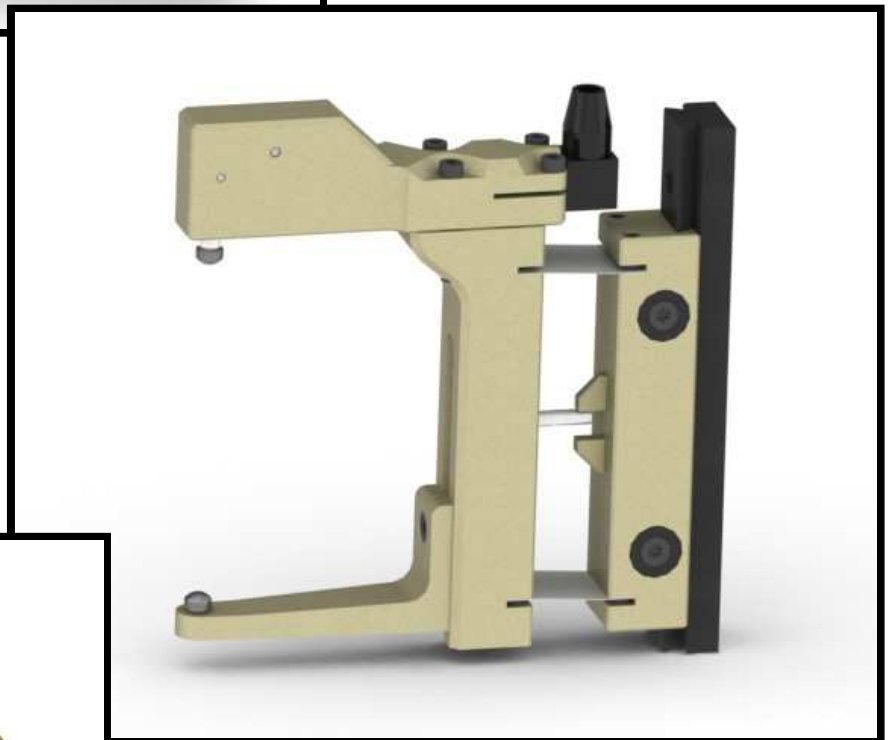
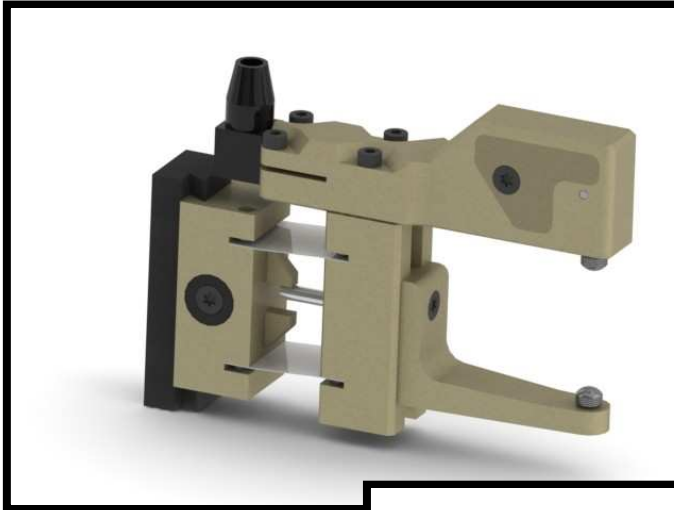

# Diameter gauge

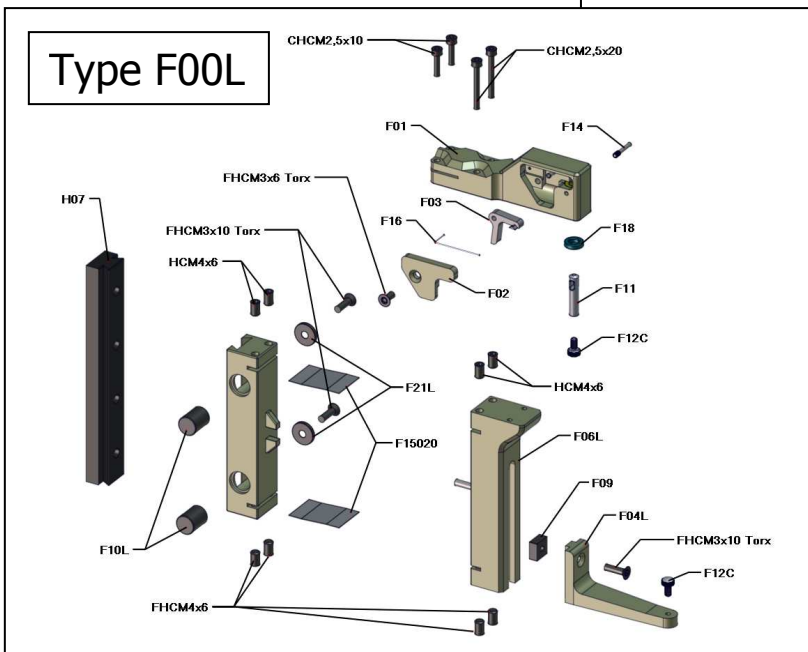
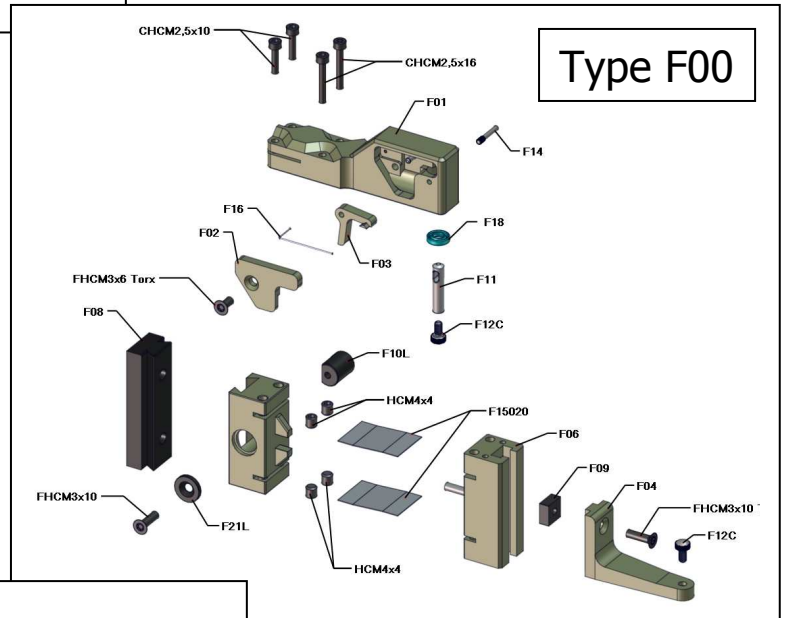
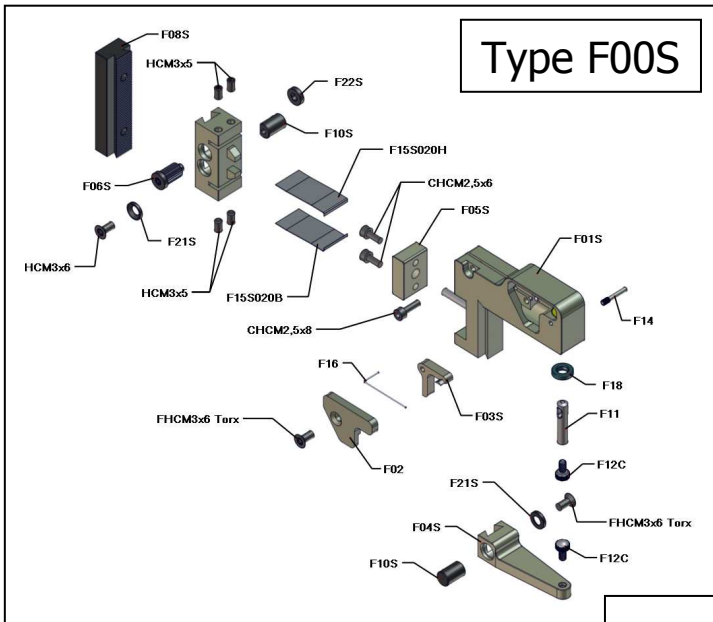

## Diameter Gauge

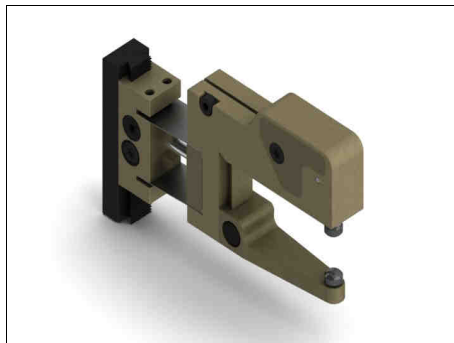

Reference : **F00S**

Designation : **Probe F00S**

Application : *Diameter measurement in process or at stati*

Sale unit : x1

Description : *This true diameter probe is used to measure external diameters up to 15mm. It is used in conjunction with the internal sensor and amplifier.*



Reference : **F00**

Designation : **Probe F00**

Application : *Diameter measurement in process or at stati*

Sale unit : x1

Description : *This true diameter probe is used to measure external diameters up to 40mm. It is used in conjunction with the internal sensor and an amplifier.*



Reference : **F00L**

Designation : **Probe F00L**

Application : *Diameter measurement on process or at stat*

Sale unit : x1

Description : *This true diameter probe is used to measure external diameters up to 70mm. It is used in conjunction with the internal sensor and an amplifier.*

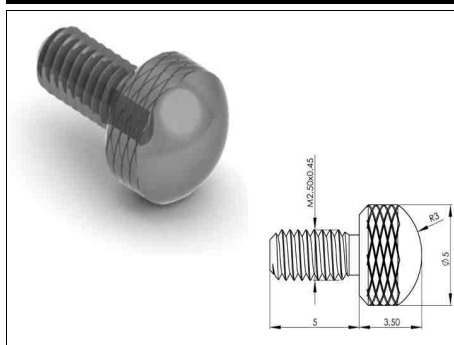

Reference : **F12C**

Designation : **Short contact tip**

Application : *F00S, F00, F00L and L00A*

Sale unit : x1

Description : *This tip contacts the part to be measured.*

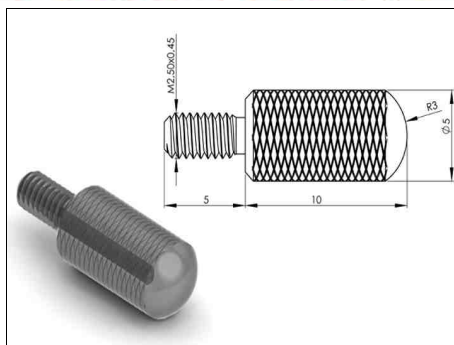

Reference : **F12L**

Designation : **Long contact tip**

Application : *F00S, F00, F00L and L00A*

Sale unit : *x1*

Description : *This tip contacts the part to be measured.*

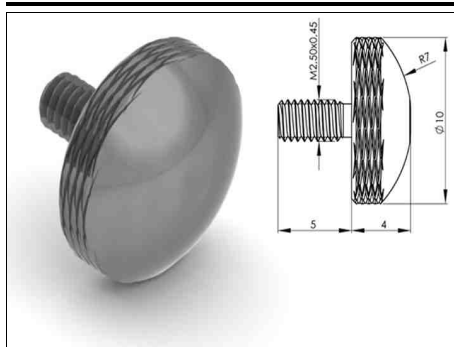

Reference : **F12B**

Designation : **Contact tip Ø10**

Application : *F00S, F00, F00L and L00A*

Sale unit : *x1*

Description : *This tip contacts the part to be measured.*

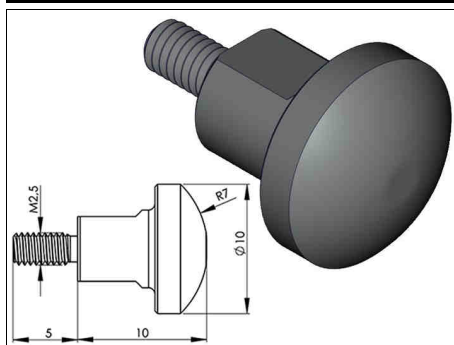

Reference : **F12BL**

Designation : **Long contact tip Ø10**

Application : *F00S, F00, F00L and L00A*

Sale unit : *x1*

Description : *This tip contacts the part to be measured.*

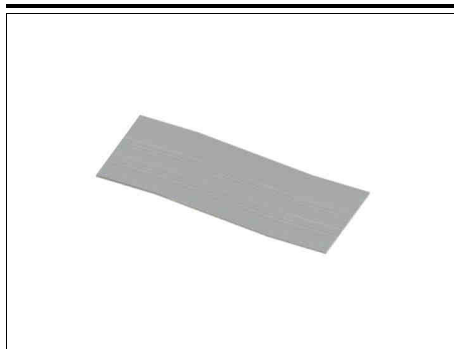

Reference : **F15020X2**

Designation : **Spring blades 0,2mm**

Application : *F00 and F00L*

Sale unit : *x2*

Description : *These spring blades are located between the QA groove (F07 or F07L) and the T groove (F06 or F06L). The springs allow the C-caliper to self-center on the part to be measured.*

*They are available in 2 strengths.*

*They are 0,20mm thick. Also available in 0,15mm (Ref.:F15015X2).*

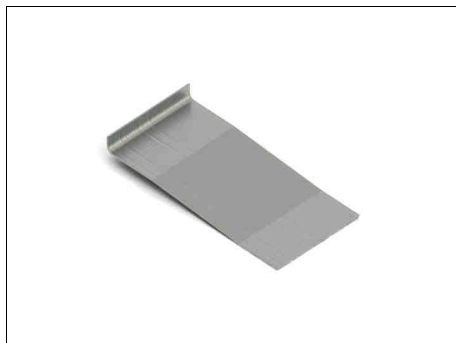

Reference : **F15S020X2**

Designation : **Spring blades 0,2mm**

Application : *F00S only*

Sale unit : x2

Description : *These spring blades are located between the QA groove and the T groove. The springs allow the C-caliper to self-center on the part to be measured. They are available in 2 strengths. They are 0,20mm thick.*

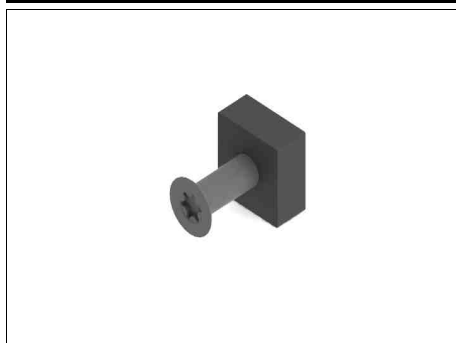

Reference : **F09X1**

Designation : **Cap + screw**

Application : *F00 and F00L*

Sale unit : x1

Description : *Delivered with 1 screw FHC M3x10*



Reference : **F10LX1**

Designation : **Clamp + washer + screw**

Application : *F00 and F00L*

Sale unit : x1

Description : *Delivered with a screw FX M3x10.*



Reference : **F10SX1**

Designation : **Clamp + washer + screw**

Application : *F00S only*

Sale unit : x1

Description : *Delivered with a screw FX M3x6*



Reference : **F08**

Designation : **Short slide**

Application : *F00 only*

Sale unit : *x1*

Description : *The QA groove F07X1 slides on the short slide in order to adjust the height of the unit. It is also used to fix the probe to the machine.*

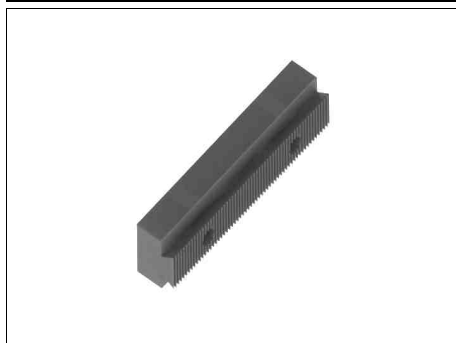

Reference : **F08S**

Designation : **Short slide**

Application : *F00S only*

Sale unit : *x1*

Description : *The QA groove slides on the short slide in order to adjust the height of the unit. It is also used to fix the probe to the machine.*

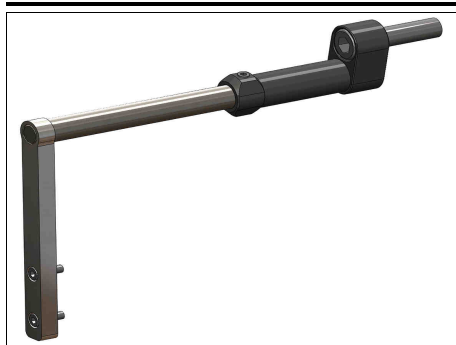

Reference : **F24S**

Designation : **Mounting body**

Application : *F00S only*

Sale unit : *x1*

Description : *Delivered with 1 screw CHC M10x35 and 1 screw M8x35*



# Gauge in complete kit

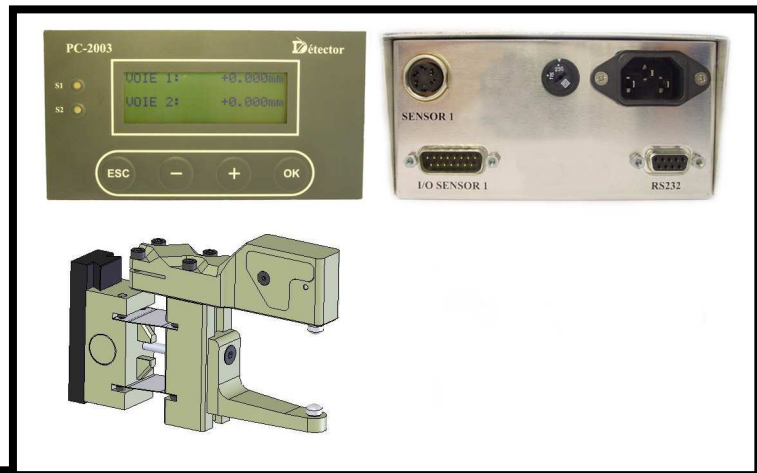

## Gauge in complete kit



Reference : **PC2003B**

Designation : **Dual channel amplifier**

Application : *Amplifier usable with all gauges*

Sale unit : x1

Description : *This amplifier can be used with all Détector length or diameter gauges. This dual channel unit allows the use of 2 sensors independently or coupled. For more information concerning the installation, please refer to the user's guide for the PC2003 amplifier.*

*Kit includes:*

- 1 dual channel amplifier
- 1 power supply cable PC03D
- 2 input/output SUB-D15 cables PC04
- 1 set of 2 fixing squares PC11X2
- 1 PC2003 Electronic Amplifier User's Guide
- 1 Mechanical Installation and Sensor Adjustment Manual



Reference : **PC2003B-DF**

Designation : **Dual channel amplifier + 1 gauge F00**

Application : *Amplifier usable with all gauges*

Sale unit : x1

Description : *This amplifier can be used with all Détector length or diameter gauges. This dual channel units allows the use of 2 sensors independently or coupled. For more information concerning the installation, please refer to the user's guide for the PC2003 amplifier.*

*Kit includes:*

- 1 dual channel amplifier
- 1 LvdT sensor PC02R
- 1 Probe F00 or F00L
- 1 power supply cable PC03D
- 2 input/output SUB-D15 cables PC04
- 1 set of 2 fixing squares PC11X2
- 1 additional probe tip F12L
- 1 PC2003 Electronic Amplifier User's Guide
- 1 Mechanical Installation and Sensor Adjustment Manual



Reference : **PC2003B-DF/DF**

Designation : **Dual channel amplifier + 2 gauges F00**

Application : *Amplifier usable with all gauges*

Sale unit : x1

Description : *This amplifier can be used with all Détector length or diameter gauges. This dual channel unit allows the use of 2 sensors independently or coupled.  
For more information concerning the installation, please refer to the user's guide for the PC2003 amplifier.*

Kit includes:

- 1 dual channel amplifier
- 2 LvdT sensors PC02R
- 2 Probes F00 or F00L
- 1 power supply cable PC03D
- 2 input/output SUB-D15 cables PC04
- 1 set of 2 fixing squares PC11X2
- 2 additional probe tips F12L
- 1 PC2003 Electronic Amplifier User's Guide
- 1 Mechanical Installation and Sensor Adjustment Manual



Reference : **PC2003B-H**

Designation : **Dual channel amplifier + 1 gauge H00**

Application : *Amplifier usable with all gauges*

Sale unit : x1

Description : *This amplifier can be used with all Détector length or diameter gauges. This dual channel unit allows the use of 2 sensors independently or coupled.  
For more information concerning the installation, please refer to the user's guide for the PC2003 amplifier.*

Kit includes:

- 1 dual channel amplifier
- 1 LvdT sensor PC02A or 1 LvdT sensor PC02APR (Protected and reinforced)
- 1 Probe H00
- 1 power supply cable PC03D
- 2 input/output SUB-D15 cables PC04
- 1 set of 2 fixing squares PC11X2
- 1 additional probe tip H0420X1
- 1 PC2003 Electronic Amplifier User's Guide
- 1 Mechanical Installation and Sensor Adjustment Manual



Reference : **PC2003B-H/DF**

Designation : **Dual channel amplifier + 1 gauge H00 + 1 gauge F00**

Application : *Amplifier usable with all gauges*

Sale unit : x1

Description : *This amplifier can be used with all Détector length or diameter gauges. This dual channel unit allows the use of 2 sensors independently or coupled.  
For more information concerning the installation, please refer to the user's guide for the PC2003 amplifier.*

Kit includes:

- 1 dual channel amplifier
- 1 Lvdts sensor PC02A or 1 Lvdts sensor PC02APR (Protected and reinforced)
- 1 Lvdts sensor PC02R
- 1 Probe H00 + 1 probe F00 or F00L
- 1 power supply cable PC03D
- 2 input/output SUB-D15 cables PC04
- 1 set of 2 fixing squares PC11X2
- 1 additional probe tip H0420X1
- 1 additional probe tip F12L
- 1 PC2003 Electronic Amplifier User's Guide
- 1 Mechanical Installation and Sensor Adjustment Manual



Reference : **PC2003B-H/H**

Designation : **Dual channel amplifier + 2 gauges H00**

Application : *Amplifier usable with all gauges*

Sale unit : x1

Description : *This amplifier can be used with all Détector length or diameter gauges. This dual channel unit allows the use of 2 sensors independently or coupled.  
For more information concerning the installation, please refer you to the user's guide for the PC2003 amplifier.*

Kit includes:

- 1 dual channel amplifier
- 2 Lvdts sensors PC02A or 2 Lvdts sensors PC02APR (Protected and reinforced)
- 2 Probes H00
- 1 power supply cable PC03D
- 2 input/output SUB-D15 cables PC04
- 1 set of 2 fixing squares PC11X2
- 2 additional probe tips H0420X1
- 1 PC2003 Electronic Amplifier User's Guide
- 1 Mechanical Installation and Sensor Adjustment Manual



Reference : **PC2003B-HD**

Designation : **Dual channel amplifier + 1 gauge H00D**

Application : *Amplifier usable with all gauges*

Sale unit : x1

Description : *This amplifier can be used with all Détector length or diameter gauges. This dual channel unit allows the use of 2 sensors independently or coupled. For more information concerning the installation, please refer to the user's guide for the PC2003 amplifier.*

Kit includes:

- 1 dual channel amplifier
- 1 Lvdv sensor PC02A or 1 Lvdv sensor PC02APR (Protected and reinforced)
- 1 Probe H00D
- 1 power supply cable PC03D
- 2 input/output SUB-D15 cables PC04
- 1 set of 2 fixing squares PC11X2
- 1 additional probe tip H0420X1
- 1 PC2003 Electronic Amplifier User Guide
- 1 Mechanical Installation and Sensor Adjustment Manual



Reference : **PC2003B-HD/DF**

Designation : **Dual channel amplifier + 1 gauge H00D + 1 gauge F00**

Application : *Amplifier usable with all gauges*

Sale unit : x1

Description : *This amplifier can be used with all Détector length or diameter gauges. This dual channel unit allows the use of 2 sensors independently or coupled. For more information concerning the installation, please refer to the user's guide for the PC2003 amplifier.*

Kit includes:

- 1 dual channel amplifier
- 1 Lvdv sensor PC02A or 1 Lvdv sensor PC02APR (Protected and reinforced)
- 1 Lvdv sensor PC02R
- 1 Probe H00D + 1 Probe F00 or F00L
- 1 power supply cable PC03D
- 2 input/output SUB-D15 cables PC04
- 1 set of 2 fixing squares PC11X2
- 1 additional probe tip H0420X1
- 1 additional probe tip F12L
- 1 PC2003 Electronic Amplifier User's Guide
- 1 Mechanical Installation and Sensor Adjustment Manual



Reference : **PC2003B-HDM**

Designation : **Dual channel amplifier + 1 gauge H00DM**

Application : *Amplifier usable with all gauges*

Sale unit : x1

Description : *This amplifier can be used with all Détector length or diameter gauges. This dual channel unit allows the use of 2 sensors independently or coupled. For more information concerning the installation, please refer to the user's guide for the PC2003 amplifier.*

Kit includes:

- 1 dual channel amplifier
- 1 Lvdv sensor PC02AC
- 1 Probe H00DM
- 1 power supply cable PC03D
- 2 input/output SUB-D15 cables PC04
- 1 set of 2 fixing squares PC11X2
- 1 additional probe tip H0420X1
- 1 PC2003 Electronic Amplifier User Guide
- 1 Mechanical Installation and Sensor Adjustment Manual



Reference : **PC2003B-HDM/DF**

Designation : **Dual channel amplifier + 1 gauge H00DM + 1 gauge F00**

Application : *Amplifier usable with all gauges*

Sale unit : x1

Description : *This amplifier can be used with all Détector length or diameter gauges. This dual channel unit allows the use of 2 sensors independently or coupled. For more information concerning the installation, please refer to the user's guide for the PC2003 amplifier.*

Kit includes:

- 1 dual channel amplifier
- 1 Lvdv sensor PC02AC
- 1 Lvdv sensor PC02R
- 1 Probe H00DM + 1 Probe F00 or F00L
- 1 power supply cable PC03D
- 2 input/output SUB-D15 cables PC04
- 1 set of 2 fixing squares PC11X2
- 1 additional probe tip H0420X1
- 1 additional probe tip F12L
- 1 PC2003 Electronic Amplifier User Guide
- 1 Mechanical Installation and Sensor Adjustment Manual



Reference : **PC2003B-LA**

Designation : **Dual channel amplifier + 1 gauge L00A**

Application : *Amplifier usable with all gauges*

Sale unit : x1

Description : *This amplifier can be used with all Détector length and diameter gauges. This dual channel unit allows the use of 2 sensors independently or coupled. For more information concerning the installation, please refer to the user's guide for the PC2003 amplifier.*

Kit includes:

- 1 dual channel amplifier PC2003B
- 1 LVDT sensor PC02A
- 1 probe L00A
- 1 power supply cable PC03D
- 2 input/output SUB/D15 cables PC04
- 1 set of 2 fixing squares PC11X2
- 1 set of additional probe tips + spring
- 1 PC2003 Electronic Amplifier User's Guide
- 1 Mechanical Installation and Sensor Adjustment Manual



Reference : **PC2003B-LB**

Designation : **Dual channel amplifier + 1 gauge L00B**

Application : *Amplifier usable with all gauges*

Sale unit : x1

Description : *This amplifier can be used with all Détector length and diameter gauges. This dual channel unit allows the use of 2 sensors independently or coupled. For more information concerning the installation, please refer to the user's guide for the PC2003 amplifier.*

Kit includes:

- 1 dual channel amplifier PC2003B
- 1 LVDT sensor PC02AS
- 1 probe L00B
- 1 power supply cable PC03D
- 2 input/output SUB/D15 cables PC04
- 1 set of 2 fixing squares PC11X2
- 1 set of additional probe tips + spring
- 1 PC2003 Electronic Amplifier User's Guide
- 1 Mechanical Installation and Sensor Adjustment Manual



Reference : **PC2003B-V**

Designation : **Dual channel amplifier + 1 gauge V00**

Application : *Amplifier usable with all gauges*

Sale unit : x1

Description : *This amplifier can be used with all Détector length or diameter gauges. This dual channel unit allows the use of 2 sensors independently or coupled. For more information concerning the installation, please refer to the user's guide for the PC2003 amplifier.*

Kit includes:

- 1 dual channel amplifier
- 1 Lvdv sensor PC02A or 1 Lvdv sensor PC02APR (Protected and reinforced)
- 1 Probe V00 or V00C12
- 1 power supply cable PC03D
- 2 input/output SUB-D15 cables PC04
- 1 set of 2 fixing squares PC11X2
- 1 additional probe tip V06X1
- 1 PC2003 Electronic Amplifier User Guide
- 1 Mechanical Installation and Sensor Adjustment Manual



Reference : **PC2003B-V/DF**

Designation : **Dual channel amplifier + 1 gauge V00 + 1 gauge F00**

Application : *Amplifier usable with all gauge*

Sale unit : x1

Description : *This amplifier can be used with all Détector length or diameter gauges. This dual channel unit allows the use of 2 sensors independently or coupled. For more information concerning the installation, please refer to the user's guide for the PC2003 amplifier.*

Kit includes:

- 1 dual channel amplifier
- 1 Lvdv sensor PC02A or 1 Lvdv sensor PC02APR (Protected and reinforced)
- 1 Lvdv sensor PC02R
- 1 Probe V00 or V00C12 + 1 Probe F00 or F00L
- 1 power supply cable PC03D
- 2 input/output SUB-D15 cables PC04
- 1 set of 2 fixing squares PC11X2
- 1 additional probe tip V06X1
- 1 additional probe tip F12L
- 1 PC2003 Electronic Amplifier User's Guide
- 1 Mechanical Installation and Sensor Adjustment Manual





Reference : **PC2003B-V/V**

Designation : **Dual channel amplifier + 2 gauges V00**

Application : *Amplifier usable with all gauges*

Sale unit : x1

Description : *This amplifier can be used with all Détector length or diameter gauges. This dual channel unit allows the use of 2 sensors independently or coupled.  
For more information concerning the installation, please refer to the user's guide for the PC2003 amplifier.*

Kit includes:

- 1 dual channel amplifier
- 2 Lvdv sensors PC02A or 2 Lvdv sensors PC02APR (Protected and reinforced)
- 2 Probes V00 or V00C12
- 1 power supply cable PC03D
- 2 input/output SUB-D15 cables PC04
- 1 set of 2 fixing squares PC11X2
- 2 additional probe tips V06X1
- 1 PC2003 Electronic Amplifier User's Guide
- 1 Mechanical Installation and Sensor Adjustment Manual



Reference : **PC2003M**

Designation : **Single channel amplifier**

Application : *Amplifier usable with all gauges*

Sale unit : x1

Description : *This amplifier can be used with all Détector length or diameter gauges. This single channel unit allows the use of only 1 sensor.  
For more information concerning the installation, please refer to the user's guide for the PC2003 amplifier.*

Kit includes:

- 1 single channel amplifier
- 1 power supply cable PC03D
- 1 input/output SUB-D15 cable PC04
- 1 set of 2 fixing squares PC11X2
- 1 PC2003 Electronic Amplifier User's Guide
- 1 Mechanical Installation and Sensor Adjustment Manual



Reference : **PC2003M-DF**

Designation : **Single channel amplifier + 1 gauge F00**

Application : *Amplifier usable with all gauges*

Sale unit : x1

Description : *This amplifier can be used with all Détector length or diameter gauges. This single channel unit allows the use of only 1 sensor.  
For more information concerning the installation, please refer to the user's guide for the PC2003 amplifier.*

*Kit includes:*

- 1 single channel amplifier
- 1 Lvdt sensor PC02R
- 1 Probe F00 or F00L
- 1 power supply cable PC03D
- 1 input/output SUB-D15 cable PC04
- 1 set of 2 fixing squares PC11X2
- 1 additional probe tip F12L
- 1 PC2003 Electronic Amplifier User Guide
- 1 Mechanical Installation and Sensor Adjustment Manual



Reference : **PC2003M-H**

Designation : **Single channel amplifier + 1 gauge H00**

Application : *Amplifier usable with all gauges*

Sale unit : x1

Description : *This amplifier can be used with all Détector length or diameter gauges. This single channel unit allows the use of only 1 sensor.  
For more information concerning the installation, please refer to the user's guide for the PC2003 amplifier.*

*Kit includes:*

- 1 single channel amplifier
- 1 Lvdt sensor PC02A or 1 Lvdt sensor PC02APR (Protected and reinforced)
- 1 probe H00
- 1 power supply cable PC03D
- 1 input/output SUB-D15 cable PC04
- 1 set of 2 fixing squares PC11X2
- 1 additional probe tip H0420X1
- 1 PC2003 Electronic Amplifier User's Guide
- 1 Mechanical Installation and Sensor Adjustment Manual



Reference : **PC2003M-HD**

Designation : **Single channel amplifier + 1 gauge H00D**

Application : *Amplifier usable with all gauges*

Sale unit : x1

Description : *This amplifier can be used with all Détector length or diameter gauges. This single channel unit allows the use of only 1 sensor.  
For more information concerning the installation, please refer to the user's guide for the PC2003 amplifier.*

Kit includes:

- 1 single channel amplifier
- 1 Lvdt sensor PC02A or 1 Lvdt sensor PC02APR (Protected and reinforced)
- 1 Probe H00D
- 1 power supply cable PC03D
- 1 input/output SUB-D15 cable PC04
- 1 set of 2 fixing squares PC11X2
- 1 additional probe tip H0420X1
- 1 PC2003 Electronic Amplifier User's Guide
- 1 Mechanical Installation and Sensor Adjustment Manual



Reference : **PC2003M-HDM**

Designation : **Single channel amplifier + 1 gauge H00DM**

Application : *Amplifier usable with all gauges*

Sale unit : x1

Description : *This amplifier can be used with all Détector length or diameter gauges. This single channel unit allows the use of only 1 sensor.  
For more information concerning the installation, please refer to the user's guide for the PC2003 amplifier.*

Kit includes:

- 1 single channel amplifier
- 1 Lvdt sensor PC02AC
- 1 Probe H00DM
- 1 power supply cable PC03D
- 1 input/output SUB-D15 cable PC04
- 1 set of 2 fixing squares PC11X2
- 1 additional probe tip H0420X1
- 1 PC2003 Electronic Amplifier User's Guide
- 1 Mechanical Installation and Sensor Adjustment Manual

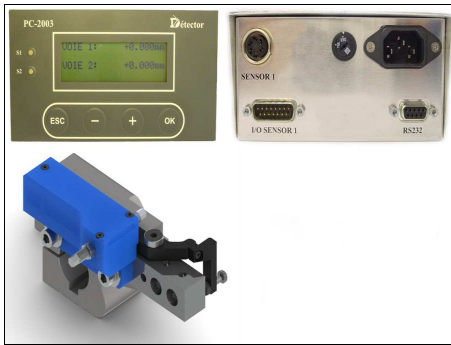

Reference : **PC2003M-LA**

Designation : **Single channel amplifier + 1 gauge L00A**

Application : *Amplifier usable with all gauges*

Sale unit : x1

Description : *This amplifier can be used with all Détector length and diameter gauges. This single channel unit allows the use of only 1 sensor.*

*For more information concerning the installation, please refer to the user's guide for the PC2003 amplifier.*

*Kit includes:*

- 1 single channel amplifier PC2003
- 1 LVDT sensor PC02A
- 1 probe L00A
- 1 power supply cable PC03D
- 1 input/output SUB/D15 cable PC04
- 1 set of 2 fixing squares PC11X2
- 1 set of additional probe tips + spring
- 1 PC2003 Electronic Amplifier User's Guide
- 1 Mechanical Installation and Sensor Adjustment Manual



Reference : **PC2003M-LB**

Designation : **Single channel amplifier + 1 gauge L00B**

Application : *Amplifier usable with all gauges*

Sale unit : x1

Description : *This amplifier can be used with all Détector length and diameter gauges. This single channel unit allows the use of only 1 sensor.*

*For more information concerning the installation, please refer to the user's guide for the PC2003 amplifier.*

*Kit includes:*

- 1 single channel amplifier PC2003
- 1 LVDT sensor PC02AS
- 1 probe L00B
- 1 power supply cable PC03D
- 1 input/output SUB/D15 cable PC04
- 1 set of 2 fixing squares PC11X2
- 1 set of additional probe tips + spring
- 1 PC2003 Electronic Amplifier User's Guide
- 1 Mechanical Installation and Sensor Adjustment Manual



Reference : **ML2008-R**

Designation : **Amplifier + wire feedout gauge**

Application : *Amplifier usable with the R00 only*

Sale unit : x1

Description : *This amplifier is used to measure up to 4 feedouts.  
It is compatible with escomatic machines. (ESCO D2, D4 and Newmac)*

*For more information concerning the installation, please refer to the "ML2008 Amplifier User's Guide".*

*Kit includes:*

- 1 amplifier ML2008
- 1 gauge R00
- 1 power supply cable PC03D
- 1 input/output SUB/D15 cable PC04
- 1 set of 2 fixing squares PC11X2
- 1 set of running wheels (R20V et R21V)
- 1 ML2008 Amplifier User's Guide



Reference : **PC2003M-V**

Designation : **Single channel amplifier + 1 gauge V00**

Application : *Amplifier usable with all gauges*

Sale unit : x1

Description : *This amplifier can be used with all Détector length or diameter gauges. This single channel unit allows the use of only 1 sensor.  
For more information concerning the installation, please refer to the user's guide for the PC2003 amplifier.*

*Kit includes:*

- 1 single channel amplifier
- 1 LvdT sensor PC02A or 1 LvdT sensor PC02APR (Protected and reinforced)
- 1 Probe V00 or V00C12
- 1 power supply cable PC03D
- 1 input/output SUB-D15 cable PC04
- 1 set of 2 fixing squares PC11X2
- 1 additional probe V06X1
- 1 PC2003 Electronic Amplifier User's Guide
- 1 Mechanical Installation and Sensor Adjustment Manual



Reference : **ML2008-R/ACN**

Designation : **Amplifier + wire feedout gauge + ACN**

Application : *Amplifier usable with the R00 only*

Sale unit : x1

Description : *This amplifier is used to measure up to 4 feedouts.  
It is compatible with escomatic machines. (ESCO D2, D4 and Newmac)*

*The ACN facilitates the adjustment of the timing of the measurement evaluation signal.*

*For more information concerning the installation, please refer to the "ML2008 Amplifier User's Guide".*

*Kit includes:*

- 1 amplifier ML2008
- 1 encoder for camshaft
- 1 gauge R00
- 1 power supply cable PC03D
- 1 input/output SUB/D15 cable PC04
- 1 set of 2 fixing squares PC11X2
- 1 set of running wheels (R20V et R21V)
- 1 ML2008 Amplifier User's Guide



Reference : **ML2008-RM**

Designation : **Amplifier + wire feedout gauge**

Application : *Amplifier usable with the R00 and R00M*

Sale unit : x1

Description : *This amplifier is used to measure up to 4 feedouts.  
It is compatible with escomatic machines. (ESCO D2, D4, Newmac and Eubama)*

*For more information concerning the installation, please refer to the "ML2008 Amplifier User's Guide".*

*Kit includes:*

- 1 amplifier ML2008
- 1 gauge R00M
- 1 power supply cable PC03D
- 1 input/output SUB/D15 cable PC04
- 1 set of 2 fixing squares PC11X2
- 1 running wheels R20ML
- 1 ML2008 Amplifier User's Guide

# Befestigungselemente für Messgeräte

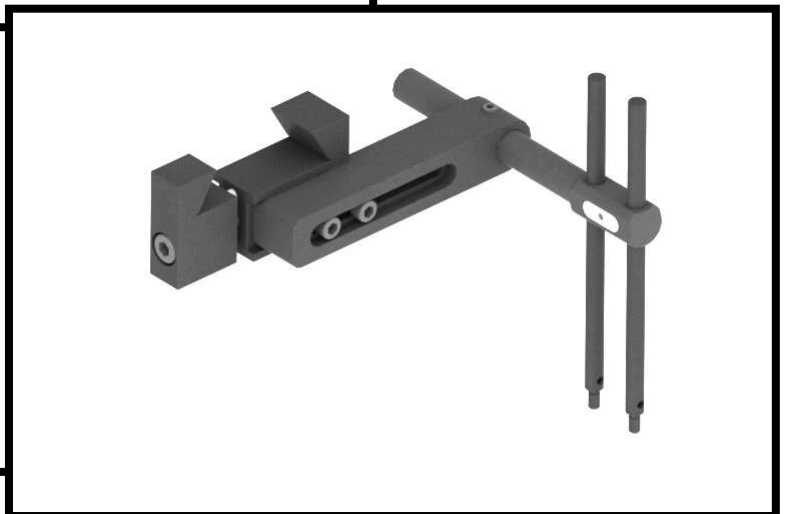
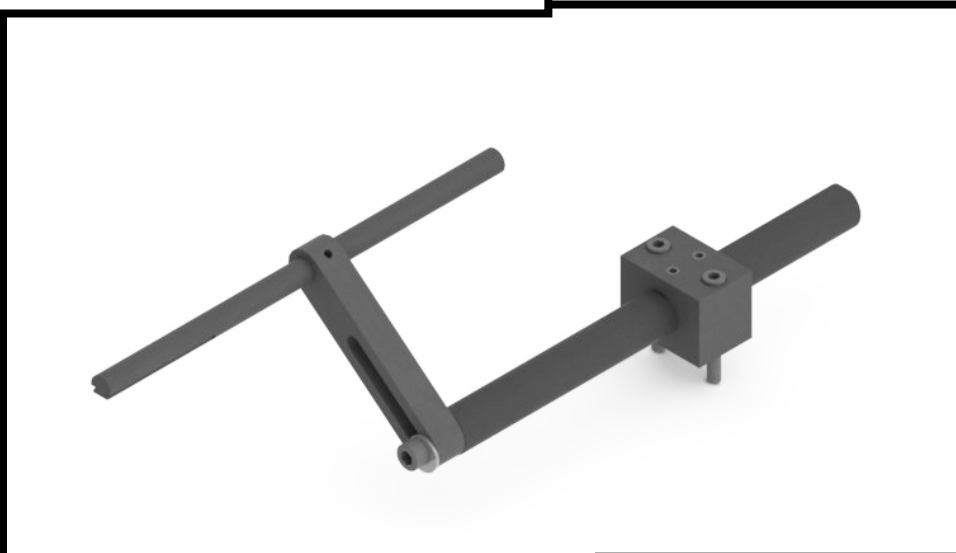
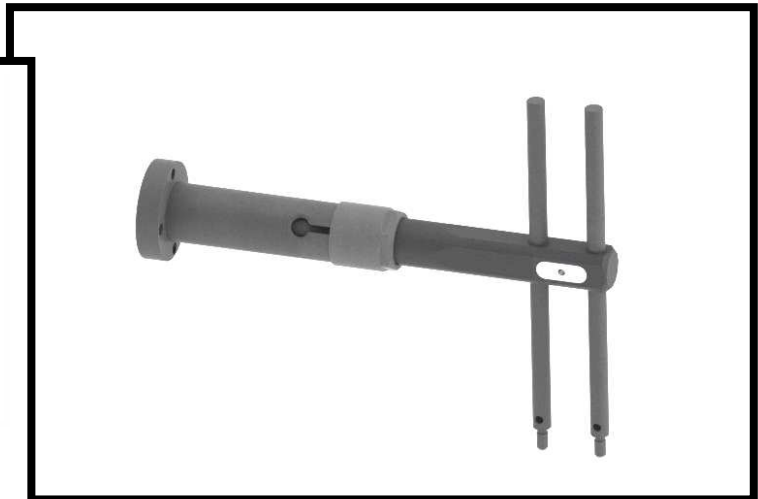
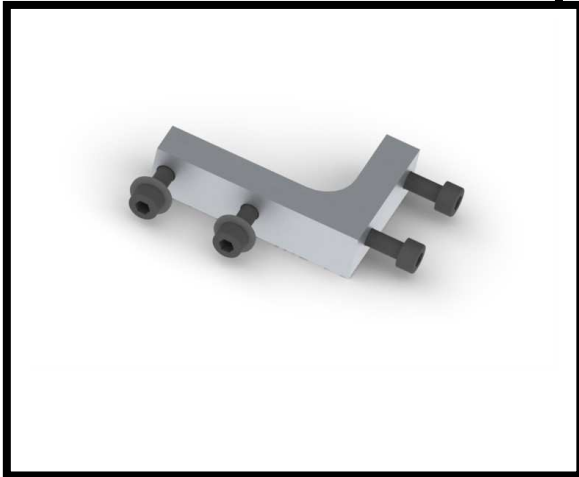

## Attachment elements for gauges

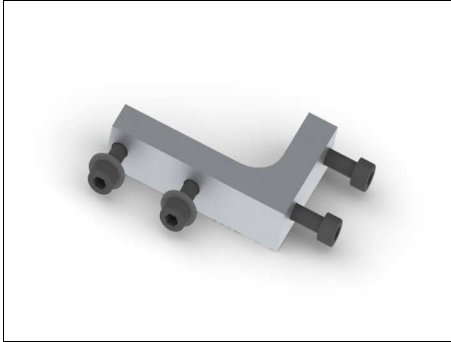

Reference : **F20X1**

Designation : **Fixing square**

Application : *F00 and F00L*

Sale unit : *x1*

Description : *This fixing square adapts the probe F00 or F00L to the standard mounting bracket H18C or H18L.*

*Delivered with all the necessary screws and washers.*



Reference : **H18L**

Designation : **Long standard mounting bracket**

Application : *H00, F00 and F00L*

Sale unit : *x1*

Description : *This mounting bracket adapts to all the machines. It is used to install the length sensor H00 or the diameter sensor F00/F00L.(+F20X1) To have more information concerning the installation, please refer you to the "Mechanical installation and sensor adjustment".*

*Delivered with all the necessary screws.*

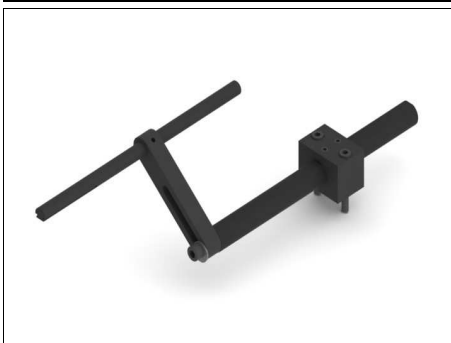

Reference : **H17**

Designation : **Mounting bracket for Gildemeister**

Application : *H00 only*

Sale unit : *x1*

Description : *This mounting bracket adapts to Gildemeister machines. It mounts on the back side of the frame. It is used to install the length sensor H00. To have more information concerning the installation, please refer you to the "Mechanical installation and sensor adjustment".*

*Delivered with all the necessary screws.*



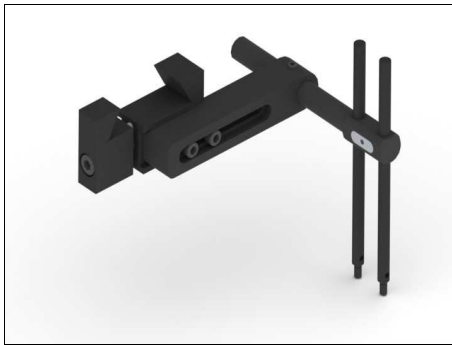

Reference : **H22**

Designation : **QA mounting bracket for Wickman 1"**

Application : *H00, F00 and F00L*

Sale unit : *x1*

Description : *This mounting bracket adapts to the 1" Wickman machines.  
It is used to install the length sensor H00 or the diameter sensor F00/F00L.(+F20X1)  
To have more information concerning the installation, please refer you to "the  
Mechanical installation and sensor adjustment".*

*Delivered with all the necessary screws.*



Reference : **H15**

Designation : **Mounting bracket for 1" Wickman**

Application : *H00, F00 and F00L*

Sale unit : *x1*

Description : *This mounting bracket adapts to the 1" Wickman machines.  
It is used to install the length sensor H00 or the diameter sensor F00/F00L.(+F20X1)  
To have more information concerning the installation, please refer you to "the  
Mechanical installation and sensor adjustment".*

*Delivered with all the necessary screws.*



Reference : **H16**

Designation : **Mounting bracket for 1"3/8 and 1"3/4  
Wickman**

Application : *H00, F00 and F00L*

Sale unit : *x1*

Description : *This mounting bracket adapts to 1"3/8 and 1"3/4 Wickman machines.  
It is used to install the length sensor H00 or the diameter sensor F00/F00L.(+F20X1)  
To have more information concerning the installation, please refer you to "the  
Mechanical installation and sensor adjustment".*

*Delivered with all the necessary screws.*

# Accessories for gauges

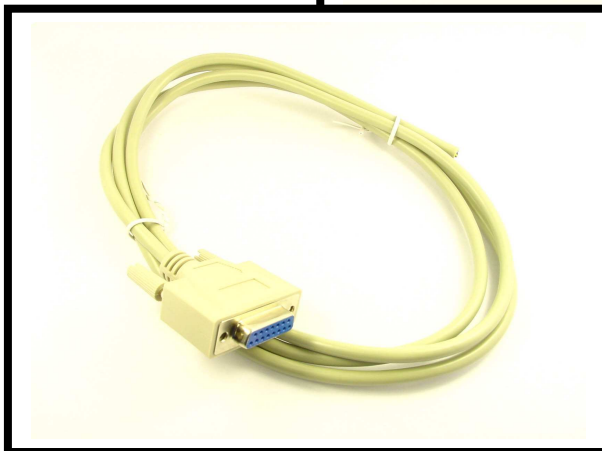
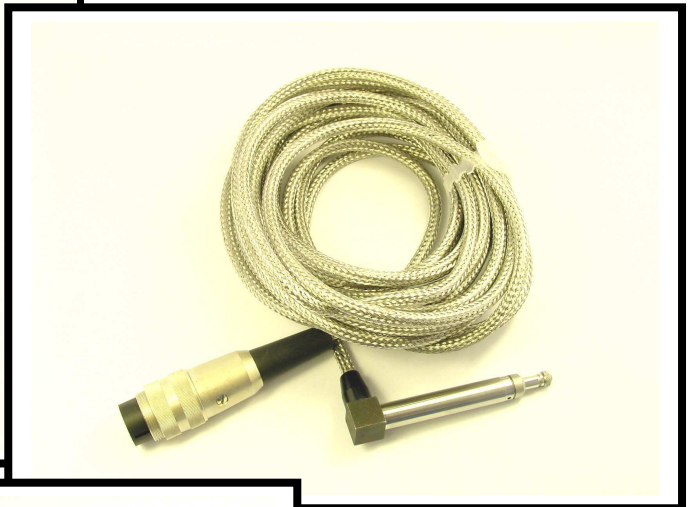
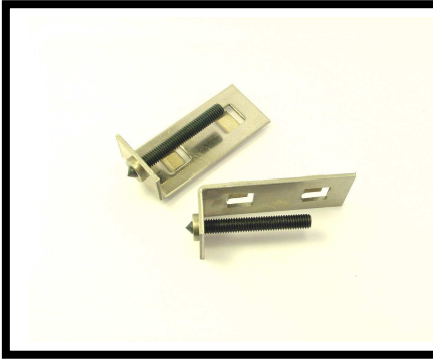

## Accessories for gauges



Reference : **PC02A**

Designation : **Axial Lvd internal sensor / 4 meters**

Application : *For probes: H00 / H00D / V00 / V00C12*

Sale unit : x1

Description : *This Lvd internal sensor is used only for the probes H00 / H00D / V00 and V00C12. It can be used with all Détector amplifiers.*

*Cable length : 4 meters*

*Precaution: Do not use without a probe.*



Reference : **PC02A15**

Designation : **Axial Lvd internal sensor / 1,5 meters**

Application : *For probes: H00 / H00D / V00 / V00C12*

Sale unit : x1

Description : *This Lvd internal sensor is used only for the probes H00 / H00D / V00 and V00C12. It can be used with all Détector amplifiers.*

*Cable length : 1.5 meters*

*Precaution: Do not use without a probe.*



Reference : **PC02APR**

Designation : **Reinforced version of the axial Lvd internal sensor / 4 meters**

Application : *For probes: H00 / H00D / V00 / V00C12*

Sale unit : x1

Description : *This Lvd internal sensor is used only for the probes H00 / H00D / V00 and V00C12. It can be used with all Détector amplifiers.*

*Cable length: 4 meters (standard)*

*Particularity: Cable radius of curvature more important than the PC02A.*

*The cable is protected by flexible tubing and heat shrinkable sheath.*

*Precaution: Do not use the sensor without a probe.*



Reference : **PC02AC**

Designation : **Axial Lvdt internal sensor / Short version / 4 meters**

Application : *H00DM only*

Sale unit : *x1*

Description : *This Lvdt internal sensor is used only for the probe H00DM. It can be used with all Détector amplifiers. Cable length : 4 meters*  
 Precaution: *Do not use without a probe.*



Reference : **PC02ACPR**

Designation : **Reinforced version of the Axial Lvdt internal sensor / Short version / 4 meters**

Application : *H00DM only*

Sale unit : *x1*

Description : *This Lvdt internal sensor is used only for the probe H00DM. It can be used with all Détector amplifiers. Cable length : 4 meters*  
 Particularity: *Cable radius of curvature more important than the PC02AC. The cable is protected by flexible tubing and heat shrinkable sheath.*  
 Precaution: *Do not use without a probe.*



Reference : **PC02AS**

Designation : **Axial Lvdt sensor / Ø6 / 4 meters**

Application : *H00DS only*

Sale unit : *x1*

Description : *This sensor is used only for the probe H00DS. It can be used with all Detector amplifiers. Body diameter: 6mm*  
 Cable length: *4 meters (standard)*  
 Precaution: *Do not use without a probe*



Reference : **PC02R**

Designation : **Radial LvdT internal sensor / 4 meters**

Application : *F00 and F00L*

Sale unit : *x1*

Description : *This LvdT internal sensor is used only for the probes F00 and F00L.  
It can be used with all Détector amplifiers.  
Cable length : 4 meters  
Precaution: Do not use without a probe.*



Reference : **PC02RPR**

Designation : **Reinforced version of the radial LvdT internal sensor / 4 meters**

Application : *F00 and F00L*

Sale unit : *x1*

Description : *This LvdT internal sensor is used only for the probes F00 and F00L.  
It can be used with all Détector amplifiers.  
Cable length : 4 meters  
Particularity: Cable radius of curvature more important than the PC02R.  
The cable is protected by flexible tubing and heat shrinkable sheath.  
Precaution: Do not use without a probe.*



Reference : **PC02ACPI**

Designation : **Axial LvdT internal sensor / Short version / 4 meters**

Application : *F00S only*

Sale unit : *x1*

Description : *This LvdT internal sensor is used only for the probe F00S.  
It can be used with all Détector amplifiers.  
Short version, reverse polarity  
Cable length : 4 meters  
Precaution: Do not use without a probe.*



Reference: **PC08015**

Designation: **Sensor extension cord / 1,5 meters**

Application: *For all internal sensors*

Sale unit: x1

Description: *This extension cord with 1 SUB-D5 male pin connector and 1 SUB-D5 femal pin connector can be used with all the Lvdt internal sensors.*  
 Length: 1,5 meters



Reference: **PC0805**

Designation: **Sensor extension cord / 5 meters**

Application: *For all internal sensors*

Sale unit: x1

Description: *This extension cord with 1 SUB-D5 male pin connector and 1 SUB-D5 femal pin connector can be used with all lvdt internal sensors.*  
 Length: 5 meters



Reference: **PC0810**

Designation: **Sensor extension cord / 10 meters**

Application: *For all internal sensors*

Sale unit: x1

Description: *This extension cord with 1 SUB-D5 male pin connector and 1 SUB-D5 femal pin connector can be used with all lvdt internal sensors.*  
 Length: 10 meters

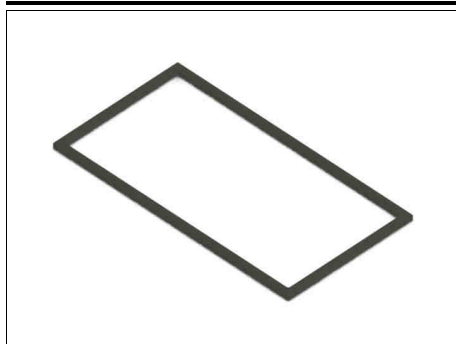

Reference: **PC15**

Designation: **Seal for amplifier**

Application: *PC2003 / ML2008 / PC300*

Sale unit: x1

Description: *This seal ensures the sealing around the amplifier fitted in the electric cabinet or in the protective enclosure (PC10).*



Reference : **PC04**

Designation : **Input / output cable SUB-D15**

Application : *PC2003 / ML2008*

Sale unit : *x1*

Description : *This cable allows the communication between the amplifier and the machine. The output / input pinlist wiring is explained in the "PC2003 amplifier user guide". Length: 3 meters (standard)*



Reference : **PC0410**

Designation : **Input / output cable SUB-D15 - 10 meters**

Application : *PC2003 / ML2008*

Sale unit : *x1*

Description : *This cable allows the communication between the amplifier and the machine. The output / input pinlist wiring is explained in the "PC2003 amplifier user guide". Length: 10 meters*



Reference : **PC04R020**

Designation : **SUB-D15 input/ output cable extension cord**

Application : *PC2003 / ML2008 / PC300*

Sale unit : *x1*

Description : *This extension cord with 1 SUB-D15 male pin connector and 1 SUB-D15 female pin connector can be used with all Détektor amplifiers. Length: 2 meters*



Reference : **PC10X1**

Designation : **Protective enclosure**

Application : *PC2003 / ML2008 / PC300*

Sale unit : *x1*

Description : *This protective enclosure is used to protect the amplifier (PC2003 / ML2008 or PC300) from oil and water. It avoids cutting the electric cabinet in order to fit the amplifier.*

Product reference	Product family	Page
<b>0102EEV110</b>	<i>Accessories for broken tool detectors</i>	<b>14</b>
<b>0102EFXGM16X1</b>	<i>Accessories for broken tool detectors</i>	<b>14</b>
<b>0102KPC</b>	<i>Accessories for broken tool detectors</i>	<b>14</b>
<b>0102NSEMV2</b>	<i>Accessories for broken tool detectors</i>	<b>13</b>
<b>0102NSEVV2</b>	<i>Accessories for broken tool detectors</i>	<b>13</b>
<b>0102PST</b>	<i>Accessories for broken tool detectors</i>	<b>12</b>
<b>0102SAI</b>	<i>Accessories for broken tool detectors</i>	<b>14</b>
<b>0102TFL</b>	<i>Accessories for broken tool detectors</i>	<b>12</b>
<b>0102VFTCX1</b>	<i>Accessories for broken tool detectors</i>	<b>12</b>
<b>0102VFTLX1</b>	<i>Accessories for broken tool detectors</i>	<b>13</b>
<b>101</b>	<i>Broken Tool Detector Type 101</i>	<b>2</b>
<b>101NU</b>	<i>Broken Tool Detector Type 101</i>	<b>2</b>
<b>101STPX1</b>	<i>Broken Tool Detector Type 101</i>	<b>3</b>
<b>101TFF</b>	<i>Broken Tool Detector Type 101</i>	<b>3</b>
<b>101TPG</b>	<i>Broken Tool Detector Type 101</i>	<b>2</b>
<b>101TPGCHD</b>	<i>Broken Tool Detector Type 101</i>	<b>3</b>
<b>110</b>	<i>Broken tool detector Type 110</i>	<b>5</b>
<b>110JRL</b>	<i>Broken tool detector Type 110</i>	<b>6</b>
<b>110NU</b>	<i>Broken tool detector Type 110</i>	<b>5</b>
<b>110STPX1</b>	<i>Broken tool detector Type 110</i>	<b>6</b>
<b>110TPG120CHDX10</b>	<i>Broken tool detector Type 110</i>	<b>5</b>
<b>110TPG120X10</b>	<i>Broken tool detector Type 110</i>	<b>5</b>
<b>202</b>	<i>Broken Tool Detector Type 202</i>	<b>8</b>
<b>202JTQ</b>	<i>Broken Tool Detector Type 202</i>	<b>10</b>
<b>202NU</b>	<i>Broken Tool Detector Type 202</i>	<b>8</b>
<b>202PEP</b>	<i>Broken Tool Detector Type 202</i>	<b>10</b>
<b>202TCX</b>	<i>Broken Tool Detector Type 202</i>	<b>8</b>
<b>202TFF</b>	<i>Broken Tool Detector Type 202</i>	<b>9</b>
<b>202TPG</b>	<i>Broken Tool Detector Type 202</i>	<b>9</b>
<b>202TPGCHD</b>	<i>Broken Tool Detector Type 202</i>	<b>9</b>
<b>202UTC</b>	<i>Broken Tool Detector Type 202</i>	<b>9</b>
<b>202YDD</b>	<i>Broken Tool Detector Type 202</i>	<b>8</b>
<b>CHCM1.6X5X10</b>	<i>Length Gauge</i>	<b>23</b>
<b>F00</b>	<i>Diameter Gauge</i>	<b>35</b>
<b>F00L</b>	<i>Diameter Gauge</i>	<b>35</b>
<b>F00S</b>	<i>Diameter Gauge</i>	<b>35</b>
<b>F08</b>	<i>Diameter Gauge</i>	<b>38</b>
<b>F08S</b>	<i>Diameter Gauge</i>	<b>38</b>
<b>F09X1</b>	<i>Diameter Gauge</i>	<b>37</b>
<b>F10LX1</b>	<i>Diameter Gauge</i>	<b>37</b>
<b>F10SX1</b>	<i>Diameter Gauge</i>	<b>37</b>
<b>F12B</b>	<i>Diameter Gauge</i>	<b>36</b>



Product reference	Product family	Page
<b>F12BL</b>	<i>Diameter Gauge</i>	<b>36</b>
<b>F12C</b>	<i>Diameter Gauge</i>	<b>35</b>
<b>F12L</b>	<i>Diameter Gauge</i>	<b>36</b>
<b>F15020X2</b>	<i>Diameter Gauge</i>	<b>36</b>
<b>F15S020X2</b>	<i>Diameter Gauge</i>	<b>37</b>
<b>F20X1</b>	<i>Attachment elements for gauges</i>	<b>54</b>
<b>F24S</b>	<i>Diameter Gauge</i>	<b>39</b>
<b>H00</b>	<i>Length Gauge</i>	<b>17</b>
<b>H00D</b>	<i>Length Gauge</i>	<b>17</b>
<b>H00DM</b>	<i>Length Gauge</i>	<b>17</b>
<b>H00DS</b>	<i>Length Gauge</i>	<b>17</b>
<b>H0410PLX1</b>	<i>Length Gauge</i>	<b>18</b>
<b>H0410X1</b>	<i>Length Gauge</i>	<b>18</b>
<b>H0420PLX1</b>	<i>Length Gauge</i>	<b>18</b>
<b>H0420X1</b>	<i>Length Gauge</i>	<b>18</b>
<b>H04DS08PLX1</b>	<i>Length Gauge</i>	<b>19</b>
<b>H04DS08X1</b>	<i>Length Gauge</i>	<b>19</b>
<b>H05DS</b>	<i>Length Gauge</i>	<b>20</b>
<b>H07</b>	<i>Length Gauge</i>	<b>19</b>
<b>H07DM</b>	<i>Length Gauge</i>	<b>19</b>
<b>H07DS</b>	<i>Length Gauge</i>	<b>20</b>
<b>H08DS</b>	<i>Length Gauge</i>	<b>20</b>
<b>H15</b>	<i>Attachment elements for gauges</i>	<b>55</b>
<b>H16</b>	<i>Attachment elements for gauges</i>	<b>55</b>
<b>H17</b>	<i>Attachment elements for gauges</i>	<b>54</b>
<b>H18L</b>	<i>Attachment elements for gauges</i>	<b>54</b>
<b>H22</b>	<i>Attachment elements for gauges</i>	<b>55</b>
<b>L00A</b>	<i>Length Gauge</i>	<b>26</b>
<b>L00B</b>	<i>Length Gauge</i>	<b>26</b>
<b>L03A</b>	<i>Length Gauge</i>	<b>28</b>
<b>L03B</b>	<i>Length Gauge</i>	<b>28</b>
<b>L05B</b>	<i>Length Gauge</i>	<b>28</b>
<b>L06A</b>	<i>Length Gauge</i>	<b>28</b>
<b>L07BX1</b>	<i>Length Gauge</i>	<b>27</b>
<b>L08A</b>	<i>Length Gauge</i>	<b>29</b>
<b>L08B</b>	<i>Length Gauge</i>	<b>29</b>
<b>L09A</b>	<i>Length Gauge</i>	<b>29</b>
<b>L11B</b>	<i>Length Gauge</i>	<b>27</b>
<b>L12BX1</b>	<i>Length Gauge</i>	<b>27</b>
<b>L13A</b>	<i>Length Gauge</i>	<b>29</b>
<b>L14A-A</b>	<i>Length Gauge</i>	<b>27</b>
<b>L16A</b>	<i>Length Gauge</i>	<b>26</b>

Product reference	Product family	Page
<b>L17AX1</b>	<i>Length Gauge</i>	<b>26</b>
<b>ML2008-R</b>	<i>Gauge in complete kit</i>	<b>51</b>
<b>ML2008-R/ACN</b>	<i>Gauge in complete kit</i>	<b>52</b>
<b>ML2008-RM</b>	<i>Gauge in complete kit</i>	<b>52</b>
<b>PC02A</b>	<i>Accessories for gauges</i>	<b>57</b>
<b>PC02A15</b>	<i>Accessories for gauges</i>	<b>57</b>
<b>PC02AC</b>	<i>Accessories for gauges</i>	<b>58</b>
<b>PC02ACPI</b>	<i>Accessories for gauges</i>	<b>59</b>
<b>PC02ACPR</b>	<i>Accessories for gauges</i>	<b>58</b>
<b>PC02APR</b>	<i>Accessories for gauges</i>	<b>57</b>
<b>PC02AS</b>	<i>Accessories for gauges</i>	<b>58</b>
<b>PC02R</b>	<i>Accessories for gauges</i>	<b>59</b>
<b>PC02RPR</b>	<i>Accessories for gauges</i>	<b>59</b>
<b>PC04</b>	<i>Accessories for gauges</i>	<b>61</b>
<b>PC0410</b>	<i>Accessories for gauges</i>	<b>61</b>
<b>PC04R020</b>	<i>Accessories for gauges</i>	<b>61</b>
<b>PC08015</b>	<i>Accessories for gauges</i>	<b>60</b>
<b>PC0805</b>	<i>Accessories for gauges</i>	<b>60</b>
<b>PC0810</b>	<i>Accessories for gauges</i>	<b>60</b>
<b>PC10X1</b>	<i>Accessories for gauges</i>	<b>61</b>
<b>PC15</b>	<i>Accessories for gauges</i>	<b>60</b>
<b>PC2003B</b>	<i>Gauge in complete kit</i>	<b>40</b>
<b>PC2003B-DF</b>	<i>Gauge in complete kit</i>	<b>40</b>
<b>PC2003B-DF/DF</b>	<i>Gauge in complete kit</i>	<b>41</b>
<b>PC2003B-H</b>	<i>Gauge in complete kit</i>	<b>41</b>
<b>PC2003B-H/DF</b>	<i>Gauge in complete kit</i>	<b>42</b>
<b>PC2003B-H/H</b>	<i>Gauge in complete kit</i>	<b>42</b>
<b>PC2003B-HD</b>	<i>Gauge in complete kit</i>	<b>43</b>
<b>PC2003B-HD/DF</b>	<i>Gauge in complete kit</i>	<b>43</b>
<b>PC2003B-HDM</b>	<i>Gauge in complete kit</i>	<b>44</b>
<b>PC2003B-HDM/DF</b>	<i>Gauge in complete kit</i>	<b>44</b>
<b>PC2003B-LA</b>	<i>Gauge in complete kit</i>	<b>45</b>
<b>PC2003B-LB</b>	<i>Gauge in complete kit</i>	<b>45</b>
<b>PC2003B-V</b>	<i>Gauge in complete kit</i>	<b>46</b>
<b>PC2003B-V/DF</b>	<i>Gauge in complete kit</i>	<b>46</b>
<b>PC2003B-V/V</b>	<i>Gauge in complete kit</i>	<b>47</b>
<b>PC2003M</b>	<i>Gauge in complete kit</i>	<b>47</b>
<b>PC2003M-DF</b>	<i>Gauge in complete kit</i>	<b>48</b>
<b>PC2003M-H</b>	<i>Gauge in complete kit</i>	<b>48</b>
<b>PC2003M-HD</b>	<i>Gauge in complete kit</i>	<b>49</b>
<b>PC2003M-HDM</b>	<i>Gauge in complete kit</i>	<b>49</b>
<b>PC2003M-LA</b>	<i>Gauge in complete kit</i>	<b>50</b>

Product reference	Product family	Page
<b>PC2003M-LB</b>	<i>Gauge in complete kit</i>	<b>50</b>
<b>PC2003M-V</b>	<i>Gauge in complete kit</i>	<b>51</b>
<b>R00</b>	<i>Length Gauge</i>	<b>31</b>
<b>R00M</b>	<i>Length Gauge</i>	<b>31</b>
<b>R20MV</b>	<i>Length Gauge</i>	<b>32</b>
<b>R24</b>	<i>Length Gauge</i>	<b>31</b>
<b>R25</b>	<i>Length Gauge</i>	<b>31</b>
<b>V00</b>	<i>Length Gauge</i>	<b>22</b>
<b>V00C12</b>	<i>Length Gauge</i>	<b>22</b>
<b>V02X1</b>	<i>Length Gauge</i>	<b>24</b>
<b>V03</b>	<i>Length Gauge</i>	<b>23</b>
<b>V04X1</b>	<i>Length Gauge</i>	<b>23</b>
<b>V05X1</b>	<i>Length Gauge</i>	<b>23</b>
<b>V06R22X1</b>	<i>Length Gauge</i>	<b>22</b>
<b>V06X1</b>	<i>Length Gauge</i>	<b>22</b>
<b>V10C12</b>	<i>Length Gauge</i>	<b>24</b>

manufacturer

## **DETECTOR FRANCE**

36 route des lacs – PAE des Jourdiés

74800 Saint Pierre en Faucigny

Tél : 00 33 (0)450 037 998

Fax : 00 33 (0)450 036 792

Email : [commercial@detector-france.com](mailto:commercial@detector-france.com)

[www.detector-france.com](http://www.detector-france.com)

